

Base a pavimento realizzata in mescola SBR dotata di profilo di fissaggio assicurato alla base tramite l'innovativo sistema di fusione

Ground base made of SBR compound, quipped with profile set on it through the innovative fusion system

Support de sol fabriqué en SBR et équipé d'un profil emprisonné de manière sûre grâce à un système innovant

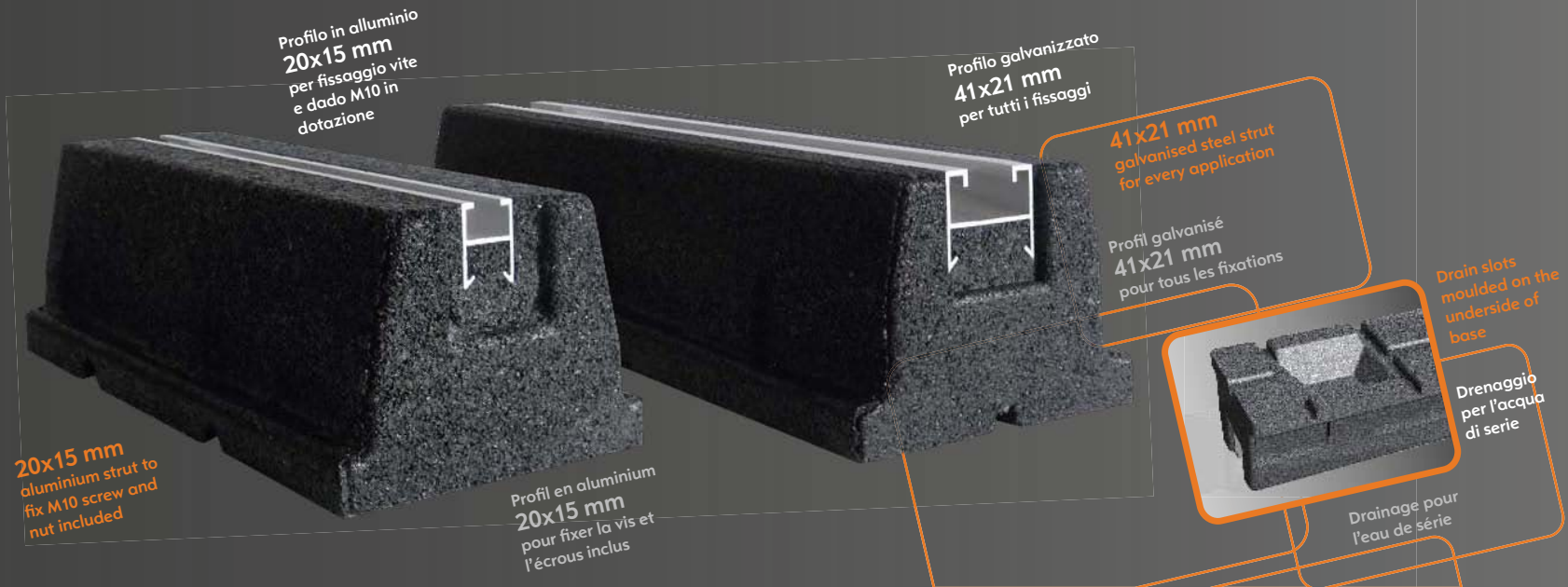

VANTAGGI

ADVANTAGES

AVANTAGES

- Assorbimento ottimale delle vibrazioni e dei rumori
- Stabilità alla macchina esterna
- Elasticità alle forti sollecitazioni
- Idoneità per l'installazione su coperture catramate
- Lunga durata nel tempo grazie ai trattamenti dei materiali utilizzati

- Great absorption of vibrations and noise
- Stability of the external machine
- Elasticity for big solicitations
- Suitable for installation on tarry roof
- Long resistance thanks to the high quality of used materials

- Grande absorbtion de vibrations et bruit
- Stabilité de la machine
- Élastique aux sollicitations fortes
- Convenable aux toits bitumeux
- Longue durée grâce à la qualité des matériaux utilisés

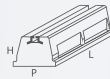

FBBASEAN00600	L600xH95xP130	500+500	2 pz	108 pz
FBBASEAN01000	L1000xH95xP130	500+500	2 pz	70 pz

Nuova linea di sistema in gomma antivibrante modulare, adattabile a molteplici applicazioni su tetti piani ed a terra

New line for a modular anti-vibration rubber system, adaptable to different applications on flat roof and ground

Nouvelle ligne pour un système en caoutchouc anti-vibration modulaire, adaptable à plusieurs utilisations, sur le toit ou au sol

Inserto metallico M10 per fissaggio profilo e/o barre filettate

Metal insert M10 to fix the profile and/or the threaded bars

Encart métallique M10 pour fixer le profil et/ou les barres filettées

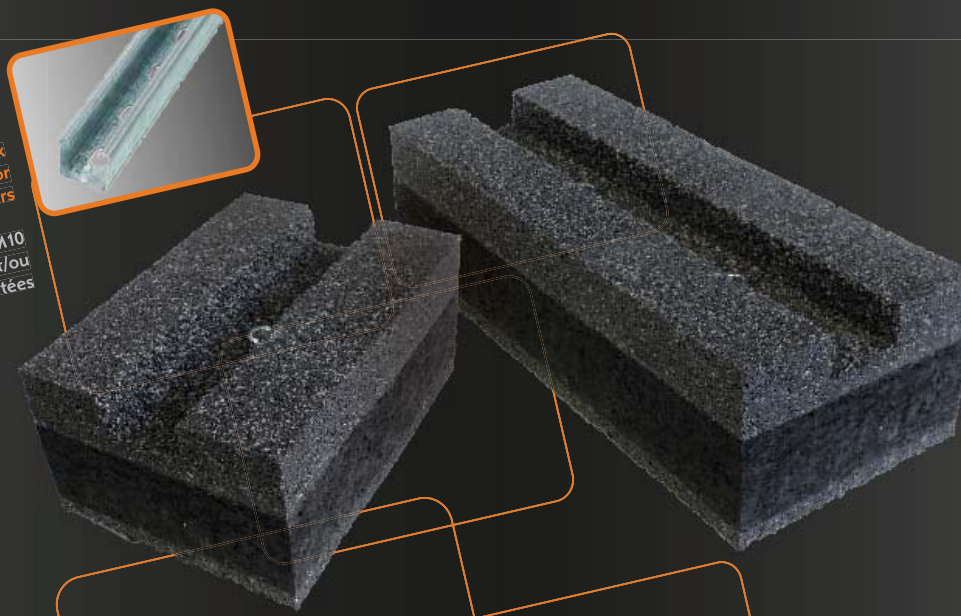

Studiato con un design semplice per una maggiore utilità tecnica, data da due strati di gomma rigida riciclata ed uno strato intermedio ammortizzante. Garantisce un'ottima compressione e tenuta con macchine pesanti

Studied with a simple design for a great technical utility, given by two layers of rigid recycled rubber and an amortizing intermediary layer. It guarantees a good compression and resistance with heavy machines

Étudié avec un design simple pour une grande utilité technique, dérivée par deux couches de gomme rigide recyclées et une couche amortissante intermédiaire. Il garantit une compression excellente et résistance avec des machines lourdes

APPLICAZIONI APPLICATIONS APPLICATIONS

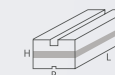
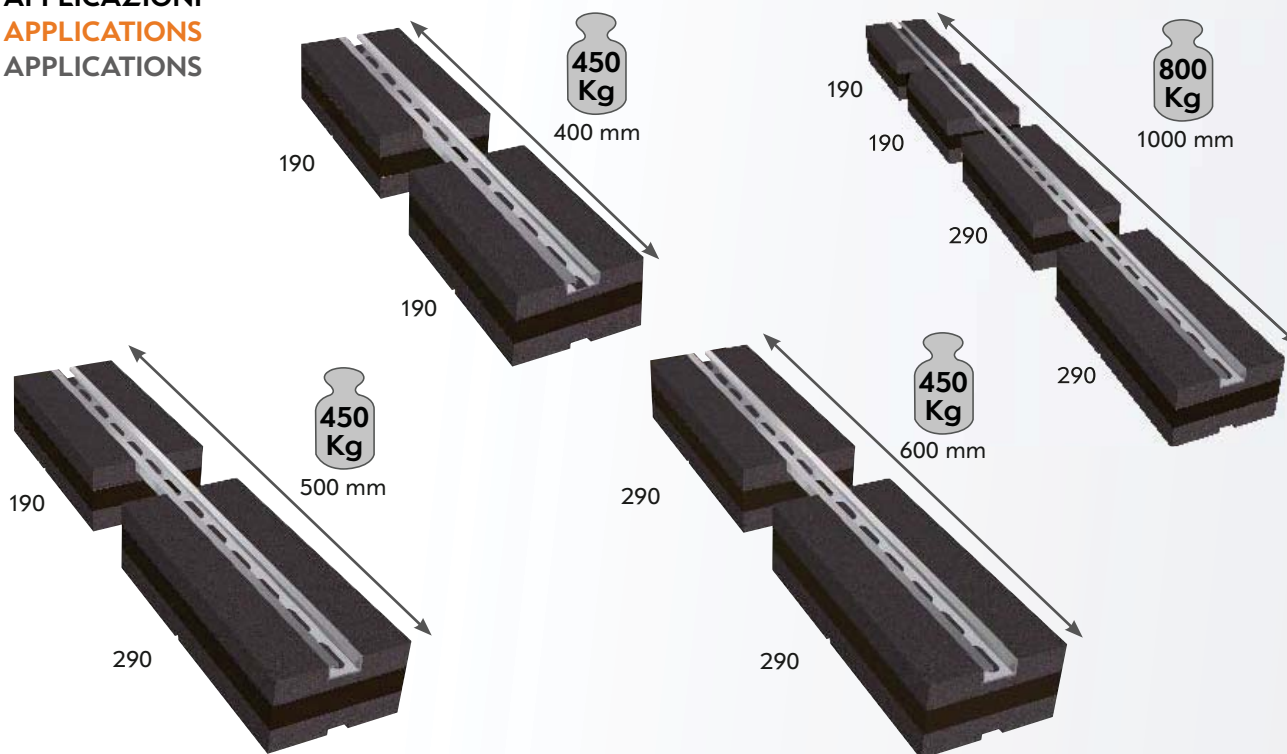

FBBASEAN00190 L190xH90xP140 220 kg 8 pz
FBBASEAN00290 L290 xH90xP140 220 kg 8 pz



FBPROFIL00000 41x20,5x2,5 3000