



fitt agix®

Designing wellness

**FITT Agix Cross 150-220 mc/h
recovery unit**

Installation manual.

Horizontal and vertical
installation

fitt agix®

First of all, we would like to thank you for having chosen one of our units.

As you will realise, you have made a winning choice by purchasing a product that represents the state of the art in domestic air-conditioning technology.

Thanks to the product you have purchased and by following the suggestions in this manual, you will benefit from optimal environmental conditions with the lowest possible energy investment.

Panasonic Corporation

Compliance

This unit complies with European directives:

- Low Voltage Directive 2014/35/EU by transposition of the following technical standards: EN 60335-1:2012 + EN 60335-2-80:2003
- EMC Directive 2014/30/EU, by transposition of technical standards: EN 55014-1:2021 + EN 55014-2:2021
- + EN IEC 61000-3-2:2019+A1:2021 + EN 61000-3-3:2013+A2:2021
- RoHS Directive 2011/65/EU by transposition of the following technical standards: EN IEC 63000:2018
- European ErP Ecodesign Regulation No. 1254/2014

Markings



CONTENTS

Compliance 2

1. General information 4

1.1 About the manual 4
 1.2 General warnings 5
 1.3 Basic safety rules. 5
 1.4 Disposal 6

2. Product introduction 7

2.1 Identification 7
 2.2 Destination of use 7
 2.3 Description of the appliance 7
 2.4 List of external components 8
 2.5 List of internal components 9
 2.6 Compatible accessories 10

3. Installation 11

3.1 Preliminary warnings 11
 3.2 Reception 11
 3.3 Dimensions and weights with packaging 11
 3.4 Handling with packaging 12
 3.5 Storage. 12
 3.6 Unpacking 12
 3.7 Handling without packaging. 13
 3.8 Installation site. 13
 3.9 Minimum installation distances. 14
 3.10 Positioning 16
 3.11 Condensate drain connection 18
 3.12 Aeraulic connections. 20
 3.13 Electrical connections 23

4. Remote control 27

4.1 Installation 27
 4.2 Electrical connections 28
 4.3 Interface 30
 4.4 Warnings. 32

5. Start-up 33

5.1 Preliminary warnings 33
 5.2 First start-up 33
 5.3 Plant delivery 35
 5.4 Switching off for extended periods 35

6. Maintenance 36

6.1 Routine maintenance 36

7. Faults and remedies 38

7.1 Preliminary warnings 38
 7.2 Troubleshooting table. 38
 7.3 Alarm table and card flashes. 39

8. Technical information 40

8.1 Technical data. 40
 8.2 Operating limits 44
 8.3 Dimensions 46
 8.4 Ecodesign classification. 51

9. Accessories 61

9.1 Electrical resistance 61
 9.2 Valves for water coils 64

1. GENERAL INFORMATION

1.1 About the manual

This manual was written to provide all the explanations for the correct management of the appliance.

- ⚠ This instruction manual is an integral part of the appliance and must therefore be kept in a safe place and must ALWAYS accompany the appliance even if it is passed on to another owner or user, or transferred to another plant. If it is damaged or lost, download a copy from the website.
- ⚠ Read this manual carefully before proceeding with any operation and follow the instructions in the individual chapters.
- ⚠ Specific warnings are given in each chapter of the document and should be read before starting operations.
- ⚠ The manufacturer accepts no liability for damage to persons or property resulting from failure to observe the regulations contained in this booklet.
- ⚠ This document is confidential under the terms of the law and may not be reproduced or passed on to third parties without the express authorisation of the Manufacturer.

Editorial pictograms

The pictograms in the following chapter provide quick and unambiguous information necessary for the correct and safe use of the machine.

Related to safety

⚠ High risk warning (bold text)

- The operation described above presents a risk of serious physical injury, fatality, major damage to the appliance and/or to the environment if not carried out in compliance with safety regulations.

⚠ Low risk warning (plain text)

- The operation described above presents a risk of minor physical injury or minor damage to the appliance and/or to the environment if not carried out in compliance with safety regulations.

⊘ Prohibition (normal text)

- Marks actions that are prohibited.

ⓘ Important information (bold text)

- This indicates important information that must be taken into account during the operations.

In the texts

Purpose of the actions

- ▶ Actions required

Expected responses following an action

- Lists

In the figures

- 1 The numbers indicate the individual components.

A Capital letters indicate a combination of components and dimensions.

- ① The white numbers in black marks indicate a series of actions to be carried out in sequence.
- Ⓐ The black letter in white identifies an image when there are several images in the same figure.

Pictograms on the product

Symbols are used in some parts of the appliance:

Related to safety



Read the instruction manual

- Read the instructions carefully before performing any operation on the appliance.



Instruction manual

- Read the information available in the technical documentation of the appliance.



Read the instruction manual

Read the instructions carefully before performing any operation on the appliance.



Instruction manual

Read the information available in the technical documentation of the appliance.



Attention electrical hazard

- Warns relevant personnel of the presence of electricity and the risk of electric shock.

Recipients

User

Non-expert person capable of operating the product in safe conditions for people, for the product itself and the environment, interpreting an elementary diagnostic of faults and abnormal operating conditions, carrying out simple adjustment, checking and maintenance operations.

Installer

Expert person qualified to position and connect (hydraulically, electrically, etc.) the unit to the plant; this person is responsible for handling and correct installation according to the instructions provided in this manual and the national standards currently in force.

Service

Expert and qualified person authorised directly by the Manufacturer to carry out all routine and supplementary maintenance operations, as well as every adjustment, check, repair and replacement of parts necessary during the life of the unit.

Organisation of the manual

The manual is divided into sections each dedicated to one or more target groups.

General information

It addresses all recipients.

It contains general information and important warnings that should be known before installing and using the appliance.

Product introduction

Addressed to all recipients, contains general information on the product.

Installation and Operation

It is addressed exclusively to the installer.

Contains specific warnings and all information necessary for positioning, mounting, connecting the device and operation.

Commissioning, maintenance and troubleshooting

They are addressed exclusively to the Authorised Service Centre.

It contains specific warnings and useful information for the most common commissioning and routine maintenance.

Technical information

It addresses all recipients.

It contains detailed technical information about the appliance.

1.2 General warnings

- ⚠ Specific warnings are given in each chapter of the document and should be read before starting operations.
- ⚠ All personnel involved must be aware of the operations and dangers that may arise when beginning all unit installation operations.
- ⚠ Installation performed outside the warnings provided in this manual and use of the appliance outside the prescribed temperature limits will invalidate the warranty.
- ⚠ Any contractual or extra-contractual liability for damage caused to persons, animals or property, due to installation, adjustment and maintenance errors or improper use is excluded. All uses not expressly indicated in this manual are not permitted.
- ⚠ The installation of the appliances must be carried out by a qualified company which, on completion of the work, will issue a declaration of compliance to the person in charge of the plant in accordance with the regulations in force and the instructions provided in the instruction booklet accompanying the appliance.
- ⚠ First start-up and repair or maintenance operations must be carried out by the Authorised Service Centre or by qualified personnel following the provisions of this manual.
- ⚠ Do not modify or tamper with the appliance as this can lead to dangerous situations.
- ⚠ Use suitable personal protective clothing and equipment during installation and/or maintenance operations. The Manufacturer is not liable for the non-observance of the current safety and accident prevention regulations.
- ⚠ In case of liquid or oil leaks, isolate the main power supply of the system and close any water valves. Promptly contact the Authorised Service Centre or professionally qualified personnel, and refrain from personally intervening on the equipment.
- ⚠ When replacing components, use only original spare parts.
- ⚠ The Manufacturer reserves the right to make changes to its models at any time to improve its product, without prejudice to the essential characteristics described in this manual. The Manufacturer is not obliged to add such modifications to machines previously manufactured, already delivered, or under construction.
- ⚠ The appliance can be used by children aged 8 years and above and by persons with reduced physical, sensory, or mental capabilities, or those lacking experience or necessary knowledge, provided they are under supervision or have been given instructions concerning the safe use of the appliance and understand the hazards involved. Children should not play with the appliance. Cleaning and maintenance intended to be carried out by the user should not be done by children without supervision.

1.3 Basic safety rules

We would like to remind you that the use of products that use electricity and water involves observing certain basic safety precautions such as:

- ⊖ It is forbidden to touch the appliance with wet or damp body parts.
- ⊖ It is forbidden to carry out any operation before disconnecting the appliance from the power supply by setting the plant master switch to "OFF".
- ⊖ It is forbidden to modify the safety or adjustment devices without the authorisation and instructions of the appliance manufacturer.
- ⊖ It is forbidden to pull, unplug or twist the electrical cables coming out of the appliance, even if it is disconnected from the mains supply.
- ⊖ It is forbidden to introduce objects and substances through the openings provided for the intake and delivery of air.
- ⊖ It is forbidden to open the access doors to the internal parts of the appliance without first setting the plant master switch to "OFF".
- ⊖ It is forbidden to dispose of packaging material and leave it within reach of children as it can be a potential hazard.

1.4 Disposal

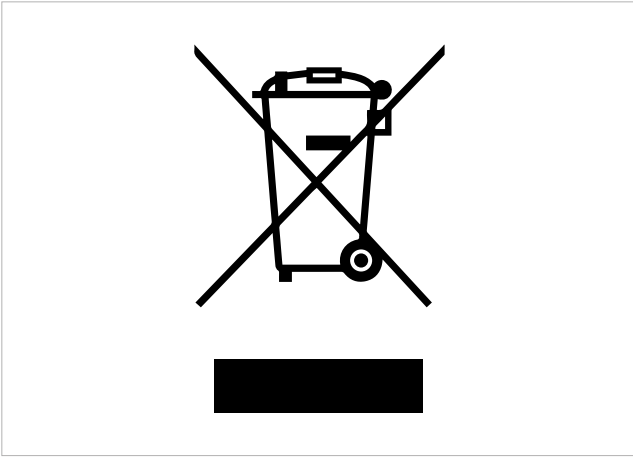

The symbol on the product or packaging indicates that the product should not be treated as normal household waste. Instead, it should be taken to an appropriate collection point for recycling of electrical, electronic, and battery equipment.

Proper disposal of this product avoids harm to humans and the environment and promotes the reuse of valuable raw materials.

For more detailed information about the recycling of this product, contact your local authority, your household waste disposal service, or the shop where you purchased the product.

Illegal disposal of the product by the user involves the application of the administrative sanctions provided for by the regulations in force.

This provision is only valid in the EU Member States.

⚠ Avoid disassembling the appliance yourself.

⚠ **Contact an Authorised Service Centre to disassemble the appliance.**

2. PRODUCT INTRODUCTION

2.1 Identification

The appliance can be identified by the rating plate:

Technical rating plate

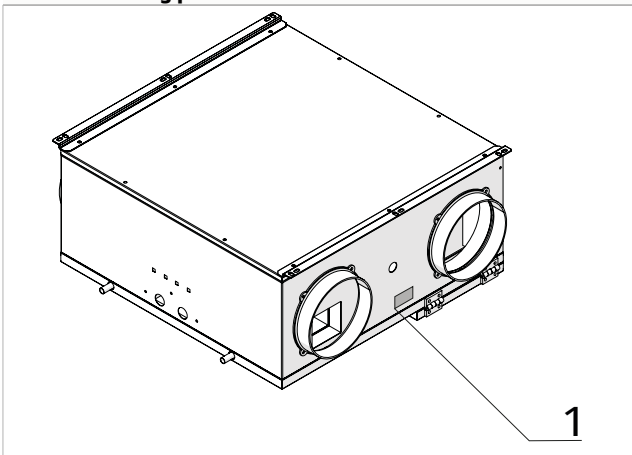

Technical rating plate

This shows the technical and performance specifications of the appliance.

⚠ Tampering with, removing or missing identification plates does not allow the product to be reliably identified by its serial number and therefore invalidates the warranty.

2.2 Destination of use

This appliance is a ventilation unit complete with heat recovery unit dedicated to changing air without wasting energy. The unit is particularly suitable for single family units, flats and in all cases where the nominal flow rates for air exchange do not exceed 500 m³/h.

The unit is designed for installation inside buildings protected from the weather in horizontal position on the ceiling or in a vertical wall position with ducted air distribution.

⚠ Size 08 is only available for horizontal ceiling installation.

2.3 Description of the appliance

Structure: self-supporting sheet metal frame, interior in high density EPS 30 kg/m³ and polyethylene foam. Carpentry and internal plugging in thick galvanised sheet metal.

Heat exchanger: counter-current type. Sensible version in polypropylene, enthalpic version with breathable membranes.

Fans: Brushless DC fans regulated by inverters allow high levels of comfort and energy efficiency with constant flow function.

Filters: EPM1 filter on fresh air and extract air with low pressure drop. Easily removable for routine maintenance.

Models: 5 sizes with different flow rates are available:

- with sensible heat exchanger
- X with enthalpy heat exchanger

Configurations: the unit is configurable in air flows according to the position of the room side and the outdoor side.

- A factory configuration

- B configuration modifiable on site

2.4 List of external components

Horizontal installation Configuration A

- 1. Extract air
- 2. Vertical condensate drain installation
- 3. Supply air
- 4. Fixing bracket

- 5. Cable grommet
- 6. Electrical connection passage
- 7. Horizontal condensate drain installation
- 8. Filter access hatch

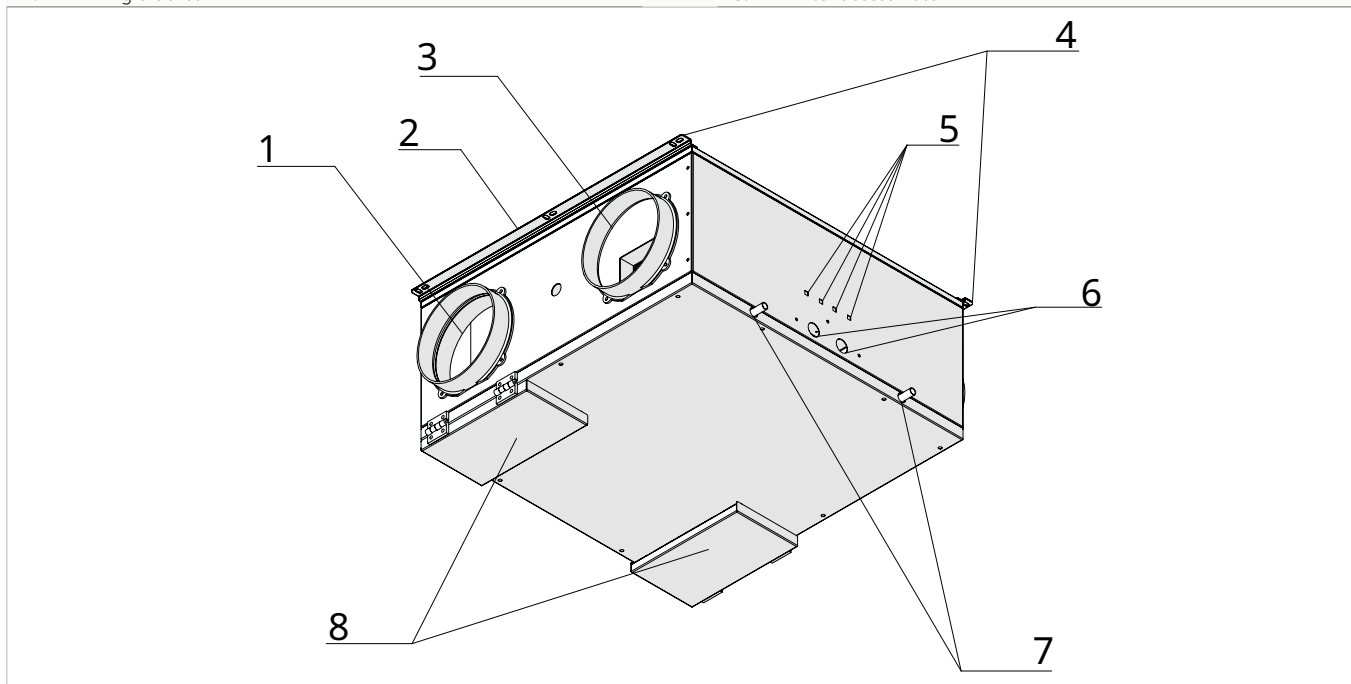

Vertical installation Configuration A

- 1. Supply air
- 2. Vertical condensate drain installation
- 3. Extract air
- 4. Horizontal condensate drain installation
- 5. Electrical connection passage

- 6. Filter access hatch
- 7. Fresh air inlet
- 8. Exhaust air
- 9. Fixing bracket
- 10. Cable grommet

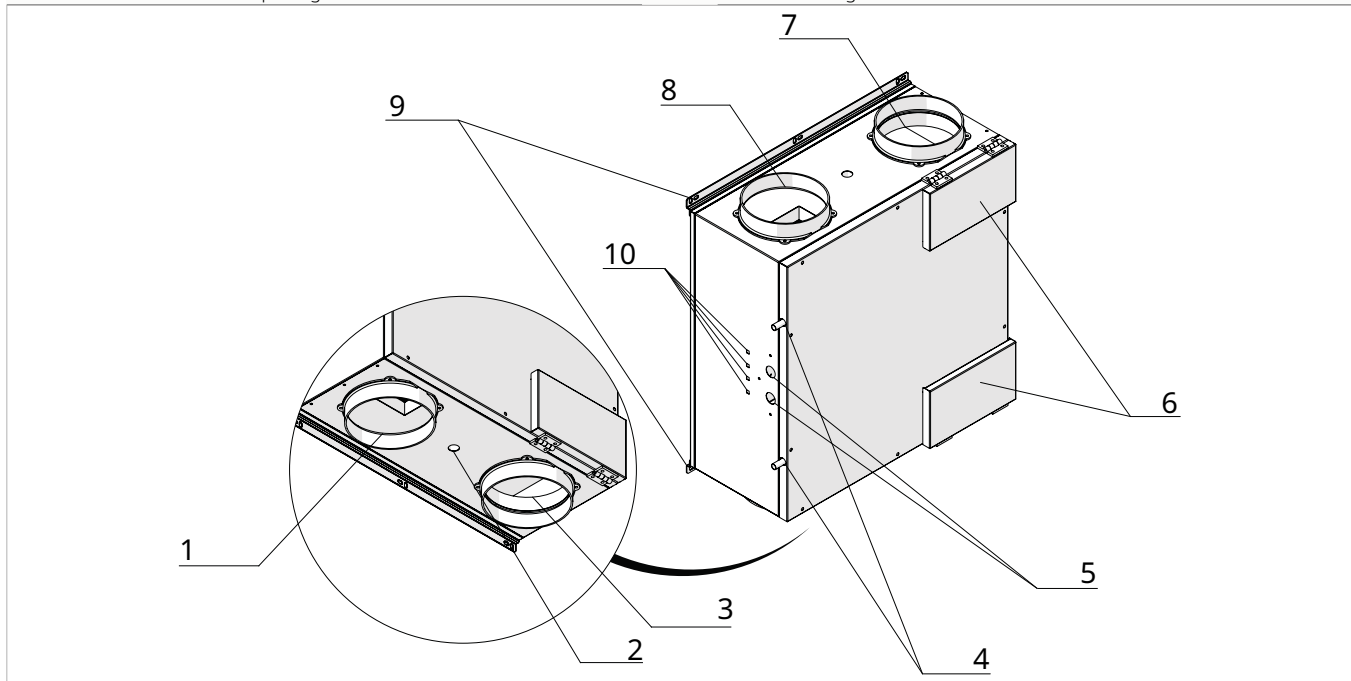

⚠ Size 08 is only available for horizontal ceiling installation.

2.5 List of internal components

Horizontal installation Configuration A

- | | | | |
|----|--------------------|----|------------------|
| 1. | Outdoor air filter | 5. | Supply fan |
| 2. | Heat exchanger | 6. | Electrical panel |
| 3. | Room air filter | 7. | Exhaust fan |
| 4. | Bypass | | |

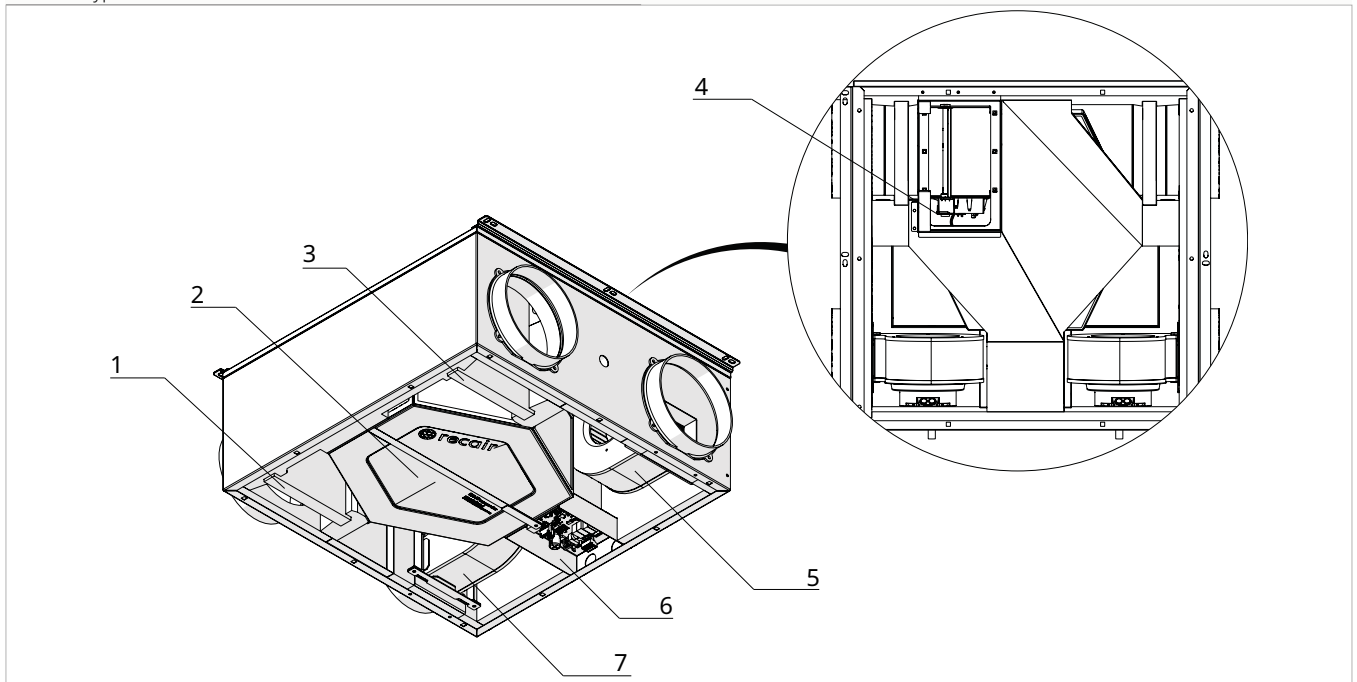

Vertical installation Configuration A

- | | | | |
|----|------------------|----|--------------------|
| 1. | Exhaust fan | 5. | Room air filter |
| 2. | Electrical panel | 6. | Outdoor air filter |
| 3. | Supply fan | 7. | Bypass |
| 4. | Heat exchanger | | |

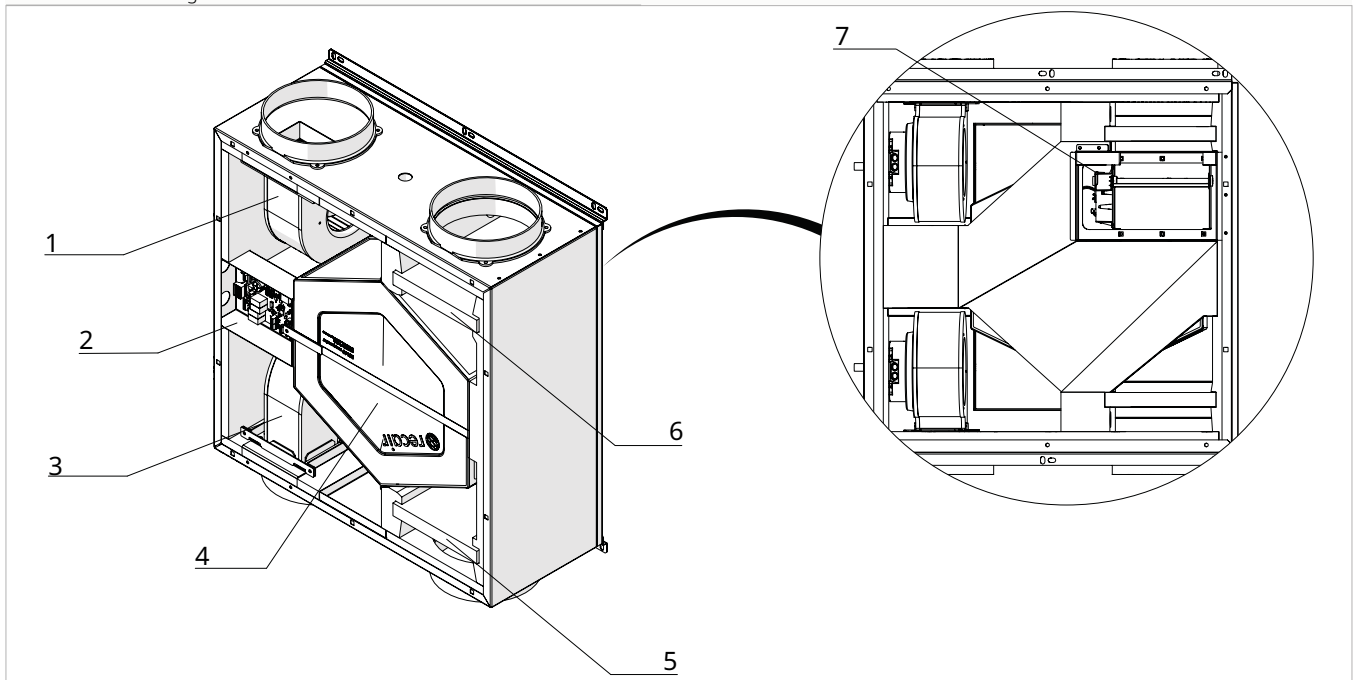

⚠ Size 08 is only available for horizontal ceiling installation.

2.6 Compatible accessories

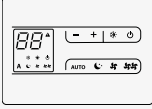
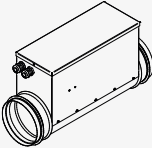
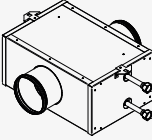
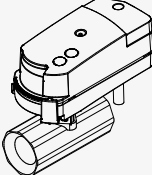
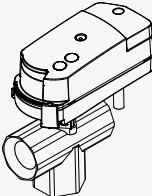
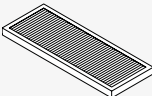
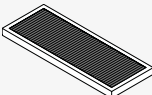
Description	Code	
Commands for I versions		
	Smart touch electronic wall control panel with integrated sensors T/RH/VOC/CO ₂ integrated Wi-Fi module in BLACK	AHRP0635
	Smart touch electronic wall control panel with integrated sensors T/RH/VOC/CO ₂ integrated Wi-Fi module in WHITE	AHRP0636
	Smart touch electronic wall control panel with integrated T/RH/VOC/CO ₂ sensors integrated Modbus communication module in BLACK	AHRP0631
	Smart touch electronic wall control panel with integrated T/RH/VOC/CO ₂ sensors integrated Modbus communication module in WHITE	AHRP0632
Auxiliary electrical coils		
	Electric post-heating coil DN 125 mm 0.5 kW	AHRP0421
	Electric post-heating coil DN 160 mm 0.5 kW	AHRP0422
Auxiliary water coils		
	Water post-heating and cooling coil DN 125 mm BAF 1	AHRP0411
	Water post-heating and cooling coil DN 160 mm BAF 2	AHRP0412
Valves for water coils		
	Motorised 2-way valve	AHRD0311
	Motorised 3-way valve	AHRD0312
Spare filters		
	Kit 2 ePM1 80% delivery filters delivery fresh air supply and extraction	AHRP0501
Active carbon spare filters		
	Kit 1 activated carbon filter	AHRP0901

3. INSTALLATION

3.1 Preliminary warnings

- ⚠ **For detailed information on the products, refer to chapter "Technical information" p. 40.**
- ⚠ The installation must be carried out by the installer. There is a risk of water leakage, electric shock or fire if the installation is not performed correctly.
- ⚠ During installation, it is necessary to observe the precautions mentioned in this manual, and on the labels affixed to the inside of the appliances, as well as to take

every precaution suggested by common sense and the safety regulations in force at the place of installation.

- ⚠ Using only the supplied installation-specific components is recommended. Use of alternative components could lead to water leakage, electric shock or fire.
- ⚠ Failure to apply the indicated rules may cause malfunctions of the appliance and relieves the Manufacturer from any warranty and from any damage caused to persons, animals or property.

3.2 Reception

Preliminary warnings

- ⚠ Upon receipt of the package check that it is not damaged, otherwise accept the goods with reservation, producing photographic evidence of any damage.
- ⚠ In the event of damage, notify the shipper by registered mail with return receipt within 3 days of receipt. Presenting photographic documentation, similar information should also be sent by email to the Manufacturer.
- ⚠ No reports of damage will be taken into account later than 3 days after delivery.

Package description

The packaging is made of suitable material and carried out by experienced personnel.

The units are all checked and tested and are delivered complete and in perfect condition.

The appliance is shipped in standard packaging consisting of a cardboard box and a set of polystyrene foam protectors, placed on a wooden pallet and secured with straps.

3.3 Dimensions and weights with packaging

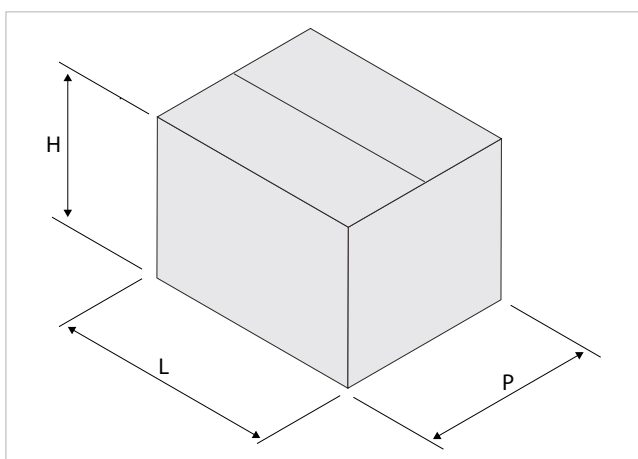

Sensible version

Models	u.m.	08	10	15	20	25
Packaging dimensions (1)						
Width	mm	650	650	650	650	650
Length	mm	700	700	700	700	700
Height	mm	240	330	330	390	390
Weight	kg	17,0	22,0	22,0	23,0	23,0
1. Excluding pallet						

Enthalpy version

Models	u.m.	08	10	15	20	25
Packaging dimensions (1)						
Width	mm	650	650	650	650	650
Length	mm	700	700	700	700	700
Height	mm	240	330	330	390	390
Weight	kg	18,0	23,0	23,0	23,5	23,5
1. Excluding pallet						

3.4 Handling with packaging

Preliminary warnings

- ⚠ The unit may only be handled by qualified personnel adequately equipped and with equipment suitable for the weight and dimensions of the unit.
- ⚠ Before each handling operation, check the lifting capacity of the machinery used in accordance with the indications on the packaging.

Handling

With pallet:

- ▶ use a forklift

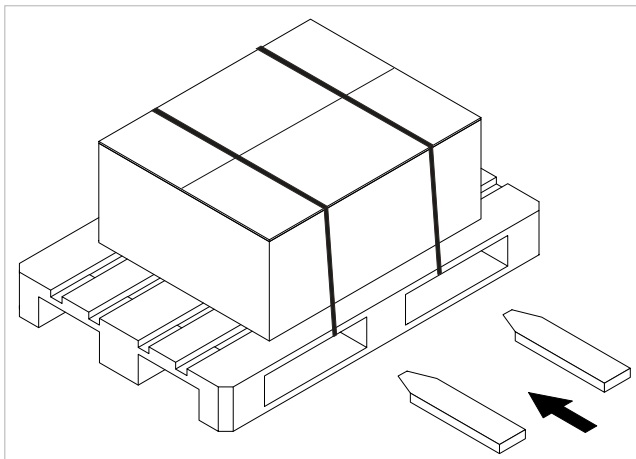

- ⚠ When the load is lifted from the ground, stay clear of the immediate and surrounding area.
- ⚠ Check the information on the packaging for the amount of stackable packages.
- ⚠ In manual operations, the maximum weight per person required by current legislation must always be observed.

Without pallet:

- ▶ use a forklift
- ⚠ The unit can only be moved manually for short trips in exceptional cases. In this case it is necessary to carefully check that the weight of the unit does not exceed what is stipulated by the regulations with respect to the number of persons employed.

3.5 Storage

Preliminary warnings

- ⚠ Stored in accordance with the applicable national regulations.

- ⚠ Store in a closed environment protected from the weather, off the ground by means of sleepers or pallets with temperatures not below 0 °C, up to a maximum of 40 °C.

3.6 Unpacking

Preliminary warnings

- ⚠ Check that the individual components are present.
- ⚠ Check that no components were damaged during transport.
- ⚠ Dispose of the packaging components following the applicable waste disposal regulations. Check for disposal arrangements with your local authority.
- ⚠ Handle with care.
- The packing material (cardboard, staples, plastic bags, etc.) must not be dispersed or abandoned in the surrounding environment and must be kept out of reach of children due to risk of hazard.

Removing the packaging

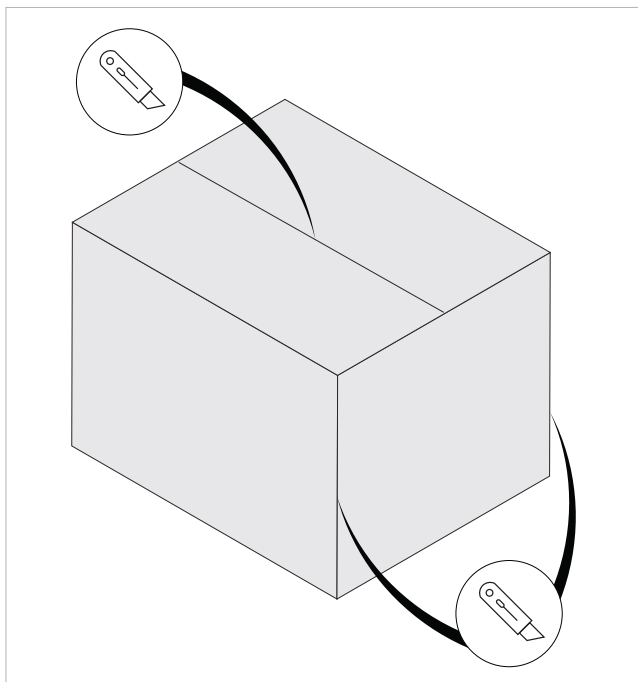

To remove the packaging:

- ▶ use a cutter
- ▶ open the cardboard packaging
- ⓘ To aid removal of the product, also cut the vertical edges.
- ▶ remove the accompanying components
- ▶ remove the polystyrene elements
- ▶ remove the appliance from the box

Accompanying material

They are included with the appliance, inside the packaging:

- Control panel user manual
- Installer manual
- Energy efficiency label
- Configuration B label
- Drain connection with siphon
- Two brackets with adjustable spacers for vertical installation
- ⚠ Check the presence of the individual components.

3.7 Handling without packaging

Preliminary warnings

- ⚠ The appliance must be handled only by qualified personnel, adequately equipped and with equipment suitable for the weight and dimensions of the appliance.
- ⚠ The unit must be handled using non-slip gloves.
- ⚠ The unit may only be handled by qualified personnel adequately equipped and with equipment suitable for the weight and dimensions of the unit.
- ⚠ Before each handling operation, check the lifting capacity of the machinery used in accordance with the indications on the packaging.
- ⚠ When the load is lifted from the ground, stay clear of the immediate and surrounding area.

- ⚠ Check the information on the packaging for the amount of stackable packages.
- ⚠ In manual operations, the maximum weight per person required by current legislation must always be observed.

Movement methods

- ▶ use a fork lift, scaffolding or other suitable lifting system
- ⚠ The unit can only be moved manually for short trips in exceptional cases. In this case it is necessary to carefully check that the weight of the unit does not exceed what is stipulated by the regulations with respect to the number of persons employed.

3.8 Installation site

The location of the appliance must be determined by the plant engineer or a competent person and must take into account both purely technical requirements and any national/local legislation in force.

The appliance is intended to be installed indoors:

- in a horizontal position fixed to the ceiling.
- in a vertical position fixed to the wall.
- ⚠ The installation position must be chosen close to a wall connected to the outside.
- ⚠ The appliance is declared IPX0 protected, therefore not suitable for installation outdoors or in rooms with the presence of water (swimming pool, etc.).

Preliminary warnings

- ⚠ Avoid installing the unit in the vicinity of:
 - obstacles or barriers that cause recirculation of the exhaust air
 - narrow places where the sound level of the appliance can be enhanced by reverberations or resonances
 - environments with the presence of flammable or explosive gases
 - very damp environments (laundries, greenhouses, bathrooms with high humidity, etc.) to prevent the formation of condensation on the external panels of the unit
 - environments with the presence of flammable or explosive gases or flammable fluids

- solar radiation and proximity to heat sources
- ⚠ **Avoid installing the unit in the vicinity of the sea. Salty atmospheres cause corrosion and oxidation of the internal components, compromising the functioning of the unit.**
- ⚠ Avoid placing the unit within 1 metre of radio and video equipment.
- ⚠ Do not install above heat sources.
- ⚠ Ensure that:
 - the installation site of the unit must be chosen with the utmost care to guarantee adequate protection from shocks and consequent damage
 - the supporting surface is capable of supporting the weight of the appliance
 - the supporting surface does not affect load-bearing building elements, piping, or power lines

- the functionality of load-bearing elements is not compromised
- there are no obstacles to the free circulation of air through the holes (plants, leaves...)
- the appliance must be installed in a position where it can be easily serviced
- the safety distances between the units and other appliances or structures are scrupulously respected so that the air entering and leaving the fans is free to circulate
- ⚠ If the unit is installed incompletely or on an unsuitable surface, it could cause damage to persons or property if it becomes detached.
- ⚠ The appliance must not be in a position where the air flow is aimed directly at a person.
- ⚠ Provide the following:
 - a drain nearby for the outflow of condensation
 - a compliant power supply nearby

3.9 Minimum installation distances

The clearance zones for the installation and maintenance of the appliance are shown in the figure below. Established spaces are necessary to avoid barriers to airflow and allow for normal cleaning and maintenance.

- ⚠ Make sure that there is sufficient space to allow the panels to be removed for routine and supplementary maintenance operations.
- ⚠ Size 08 is only available for horizontal ceiling installation.

Horizontal installation

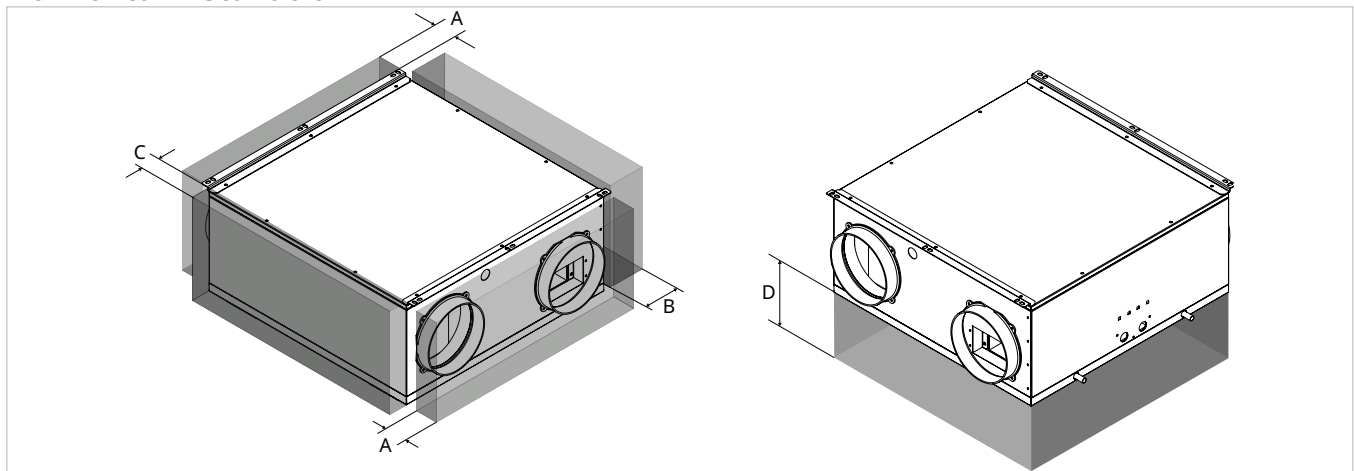

Models	u.m.	08	10	15	20	25
Minimum distances						
A	mm	10	10	10	10	10
B	mm	30	30	30	30	30
C	mm	10	10	10	10	10
D	mm	190	235	235	293	293

Vertical installation

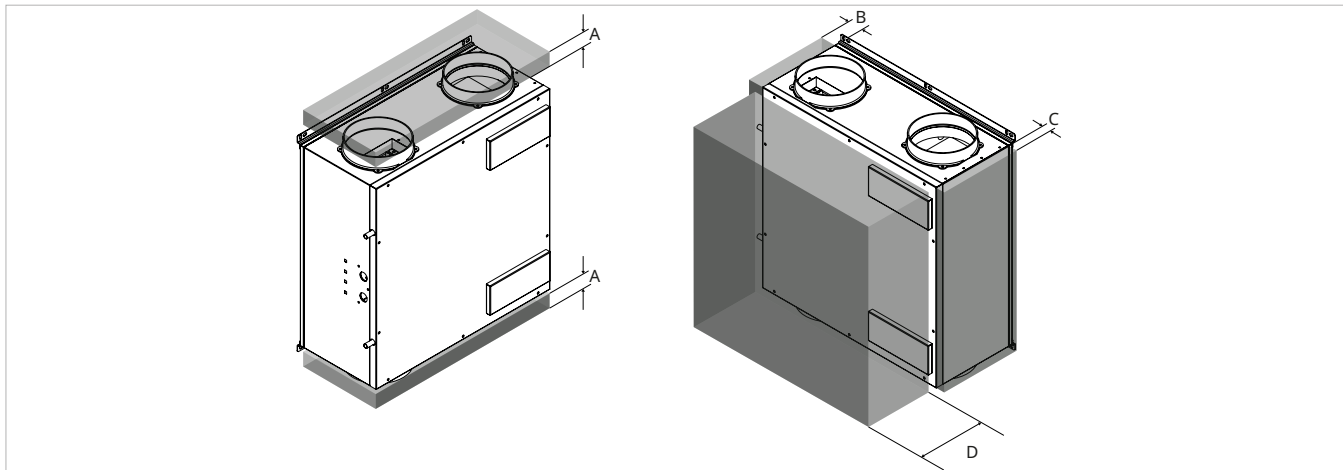

Models	u.m.	10	15	20	25
Minimum distances *					
A	mm	20	20	20	20
B	mm	30	30	30	30
C	mm	10	10	10	10
D	mm	235	235	293	293

Hatch dimensions

⚠ For installation in a ceiling, it is mandatory to create an access hatch for the inspection and maintenance of the device.

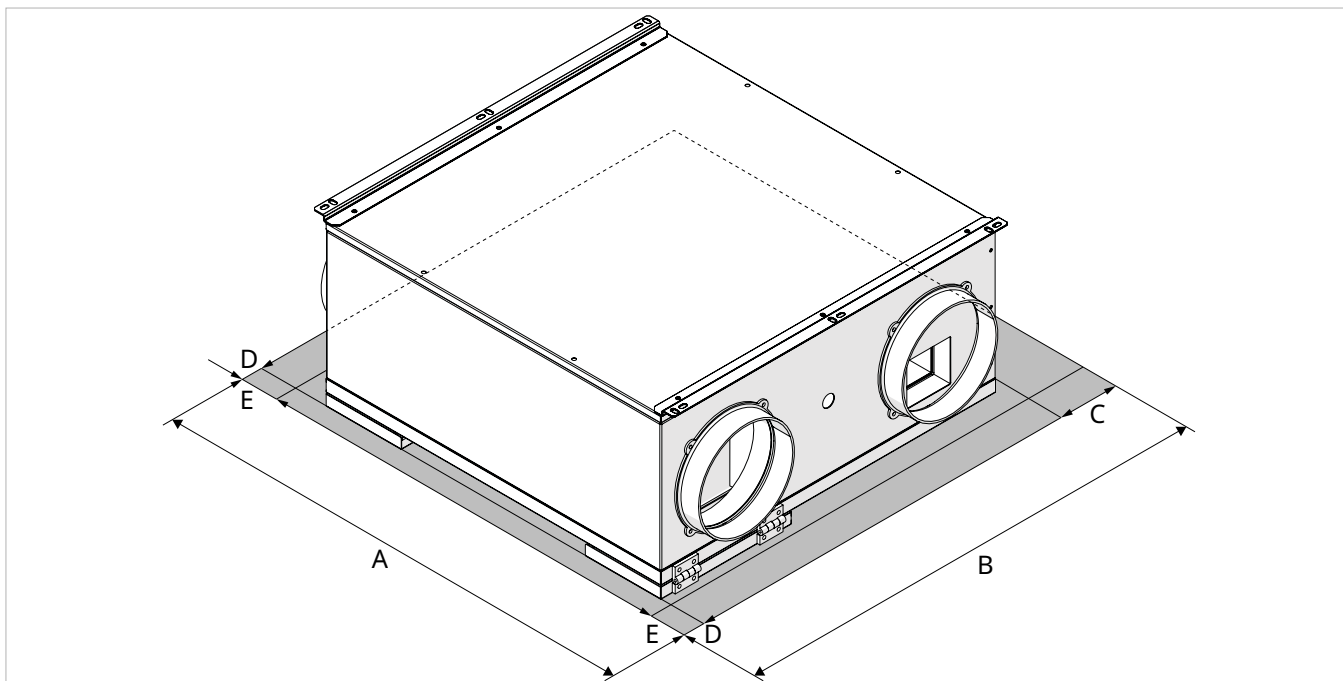

Models	u.m.	08	10	15	20	25
Hatch dimensions						
A	mm	672	672	672	672	672
B	mm	620	620	620	620	620
C	mm	30	30	30	30	30

Models	u.m.	08	10	15	20	25
D	mm	10	10	10	10	10
E	mm	10	10	10	10	10

3.10 Positioning

Preliminary warnings

⚠ **Size 08 is only available for horizontal ceiling installation.**

⚠ Check that:

- the surface supports the weight of the appliance
- the surface does not affect piping or power lines
- the functionality of load-bearing elements is not compromised

Drilling the outside wall

The external wall must be prepared with holes for air ducting.

To drill the holes:

- ▶ mark the position of the hole
 - ▶ use a drill
 - ▶ drill a guide hole
 - ▶ use a core drill
 - ▶ make a hole through the wall
 - ▶ maintain a downward slope towards the outside
- ⚠ To avoid the release of large amounts of dust and debris into the room, you are advised to couple the core drill with a vacuum system.
- ⚠ Proceed with caution near the outside wall to avoid breaking the plaster around the hole.
- ⚠ Take precautions so that the removed material does not hit people and objects below.

Installation bracket configuration

Size 10 - 15 - 20 - 25

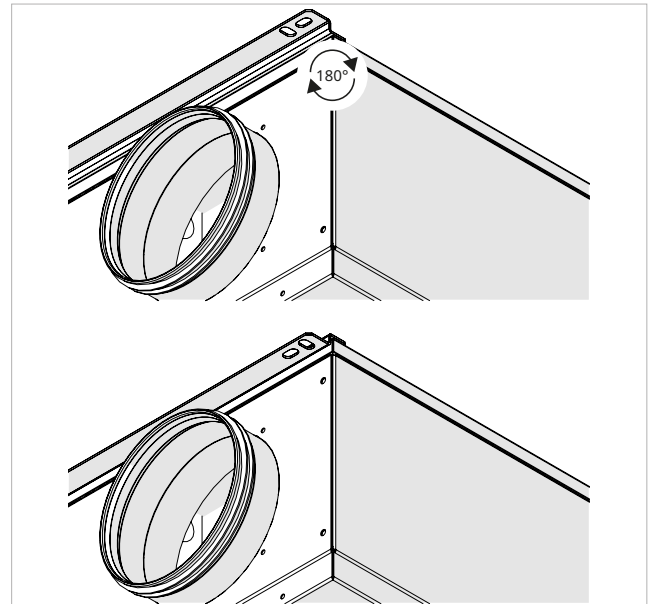

Size 08

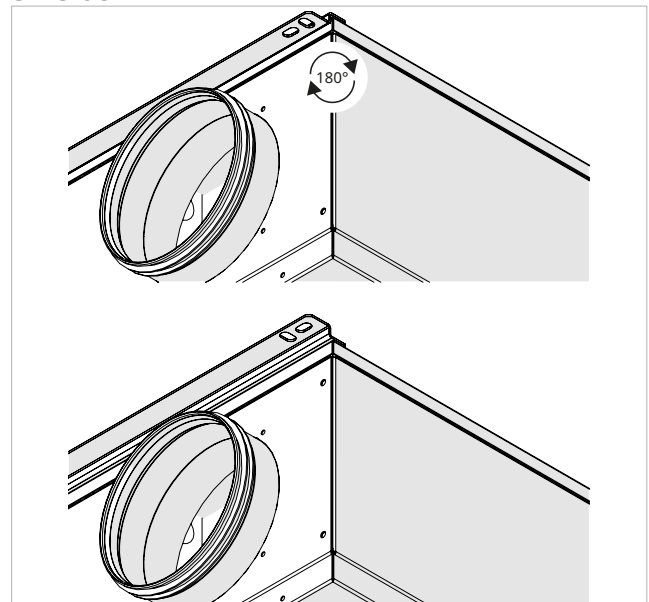

⚠ For sizes 10, 15, 20, and 25, the installation bracket is factory-supplied with the orientation upwards. It is possible to rotate it 180° to mount the unit flush against the ceiling. This option may cause vibrations, unwanted noises, and a height variation compared to the standard configuration indicated in the manual.

- ⚠ Size 08 is factory-supplied with the bracket oriented downwards, but it is possible to rotate the fixing bracket 180°. This option changes the unit's height compared to the standard one indicated in the manual.

Positioning the unit

The unit can be installed in two different ways:

- Horizontal ceiling installation
- Vertical wall installation

Horizontal ceiling installation

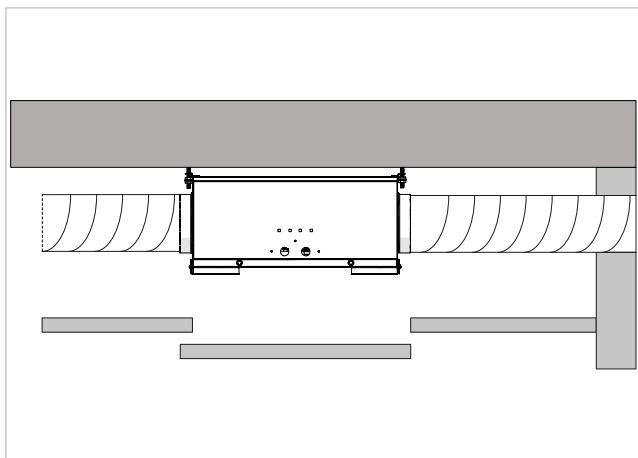
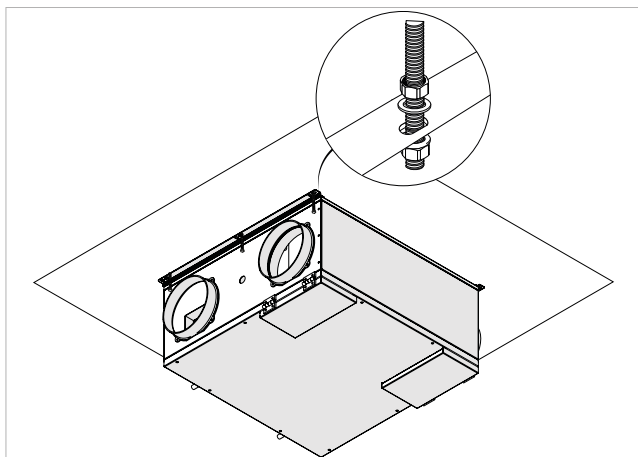

- ⚠ Check the correct orientation of the unit.
- ▶ mark the position of the fixing holes
 - ▶ use fixing systems appropriate for the type of supporting surface and the weight of the unit
 - ▶ secure the unit to the fixing system

Check that:

- it is levelled
- the minimum installation distances are respected

Vertical wall installation

The machine leaves the factory ready for horizontal installation. The position of the fixing brackets must be changed to install it in a vertical position.

- ⚠ Check the correct orientation of the unit.
 ⚠ Size 08 is only available for horizontal ceiling installation.

1. Upper bracket
2. Lower bracket

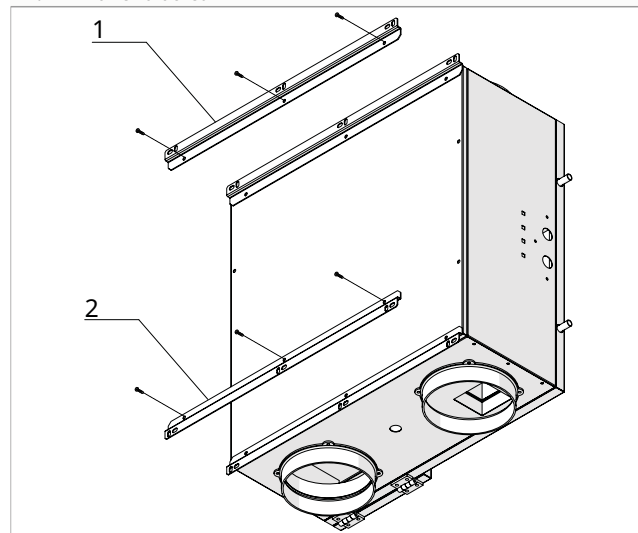

- ▶ remove the fixing screws
- ▶ remove the brackets

1. Upper bracket

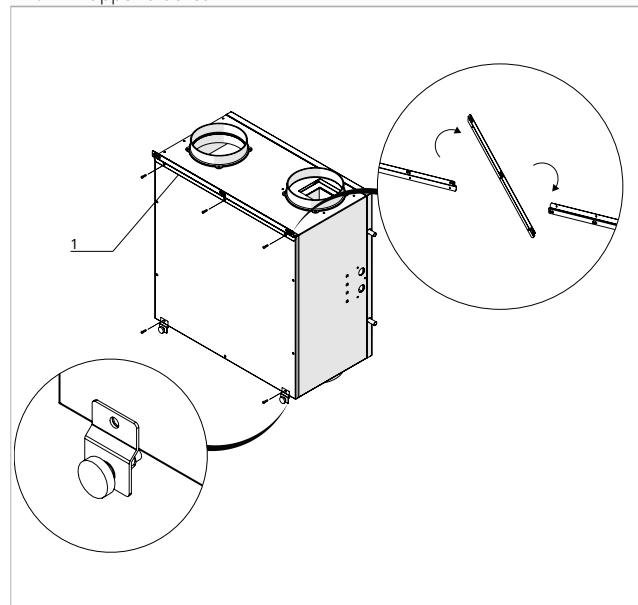

- ▶ rotate the upper bracket by 180°
- ▶ reposition the bracket on the unit
- ▶ position the brackets with adjustable spacers on the lower side

- 1. Upper bracket
- 2. Lower bracket

- 3. Spacers

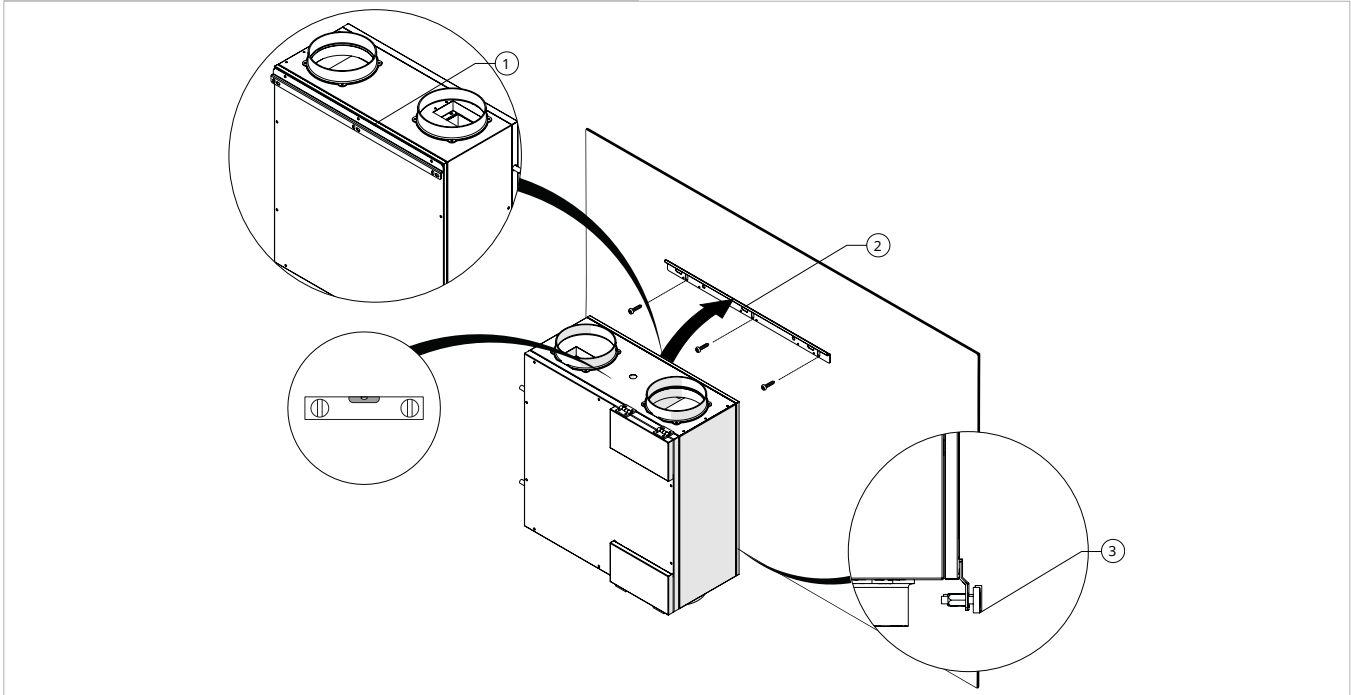

- ▶ take the lower bracket removed from the unit again
- ▶ use the lower bracket as a template
- ▶ mark the position of the fixing holes
- ▶ use screws and expansion plugs suitable for the weight of the appliance and the material of the supporting wall
- ▶ fix the lower bracket to the wall

- ▶ hook the upper bracket positioned on the device to the lower bracket positioned on the wall
- ▶ adjust the spacers

Check that:

- it is levelled
- the minimum installation distances are respected

3.11 Condensate drain connection

Preliminary warnings

- ⚠ This appliance is equipped with trays for collecting the condensate that is produced during operation. Condensate must be routed to a suitable place for drainage.
- ⚠ The appliance is equipped with two condensate drainage connections. One of the two must be used depending on the chosen configuration.
- ⚠ If the drainage line runs into a container (tank or other) it must be ensured that the container itself is hermetically sealed and most importantly it must be ensured that the drainage pipe is not immersed in water.
- ⚠ The hole for the condensate pipe must always have an downwards slope.
- ⚠ When connecting the condensate drain, take care not to crush the rubber pipe.

Attachment position

The unit has three condensate drain attachments. The size and position of the condensate drain attachments are shown below.

- 1. Vertical installation condensate drain attachment Ø 20 mm
- 2. Condensate drain connection horizontal installation configuration B Ø 12 mm
- 3. Condensate drain connection horizontal installation configuration A Ø 12 mm

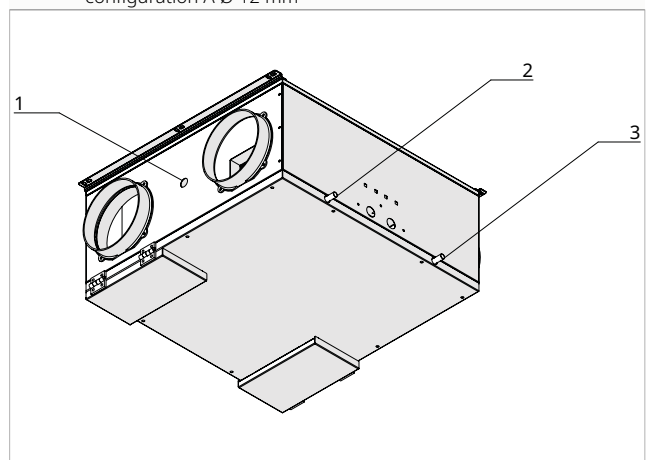

- ⚠ The unused attachments must be capped.

Connections

Unit installed horizontally on the ceiling:

1. Condensate drain connection
2. Condensate drain pipe
3. Hose clamp

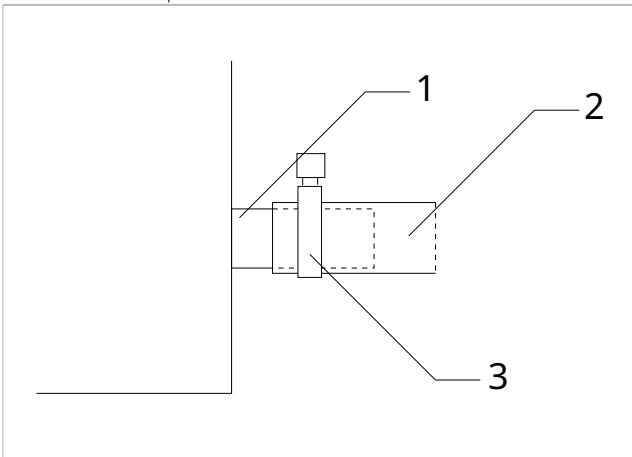

1. Unit

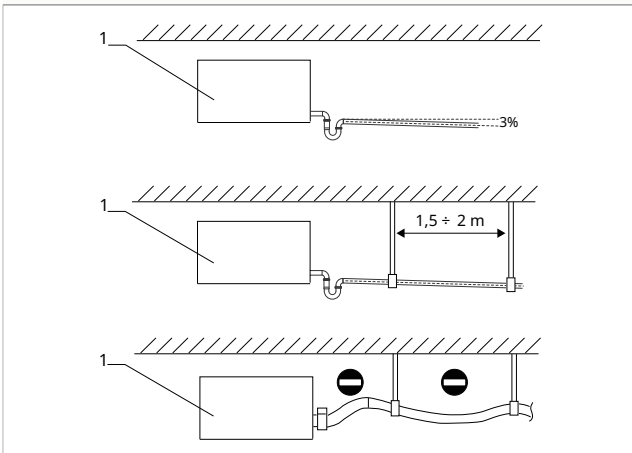

- | | |
|----|-------|
| HT | 60 mm |
| H1 | 30 mm |
| H2 | 30 mm |

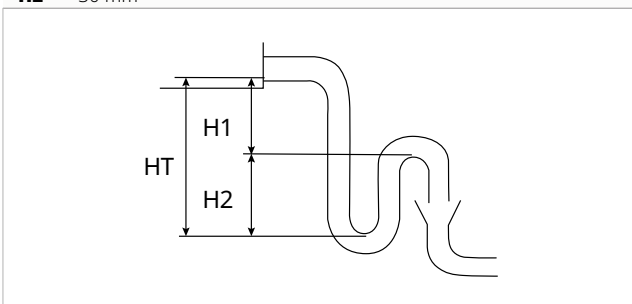

Depending on the chosen configuration:

- ▶ connect the drainage pipe to the connection provided on the unit
- ▶ install a siphon on the condensate drainage pipe near the unit
- ▶ direct the condensate drain pipe to a suitable place for draining
- ▶ maintain a minimum slope of 3% towards the drain location

- ▶ insulate junction points

⚠ **It is mandatory to install an adequate siphon on the condensate drainage pipe to prevent the negative pressure generated by the fans from obstructing the proper flow of condensate, which could lead to spillage inside the premises.**

⚠ The drainage system must include a suitable siphon to prevent unwanted air from entering the vacuum system. The siphon also prevents the entry of odours or insects.

⚠ The siphon must be fitted with a plug at the bottom or must in any case permit quick dismantling for cleaning.

⚠ Use plastic drainage pipes.

⚠ Avoid metal pipes.

⚠ Make sure all joints are sealed to prevent leakage of water.

⚠ Condensate drain pipes must be insulated for both indoor and outdoor sections to avoid condensation on the surface and/or frosting problems. The insulation must be inserted all the way to the condensate drain pipe connection on the unit.

Unit installed vertically on the wall:

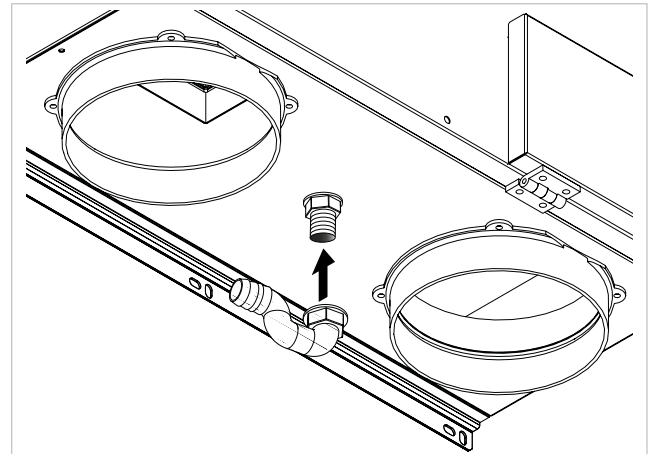

1. Drain connection with siphon
2. Condensate drain pipe
3. Hose clamp

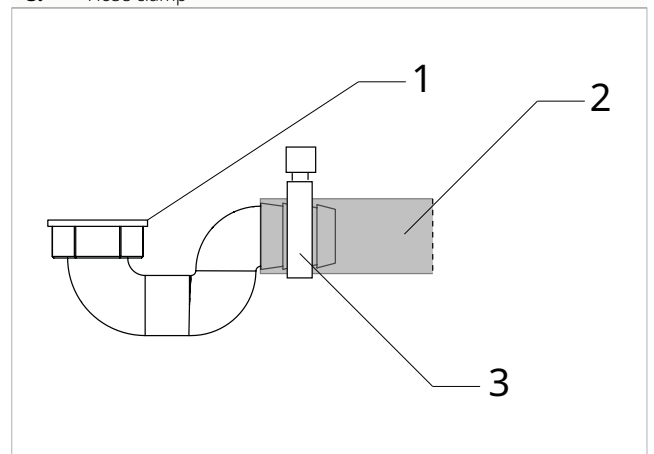

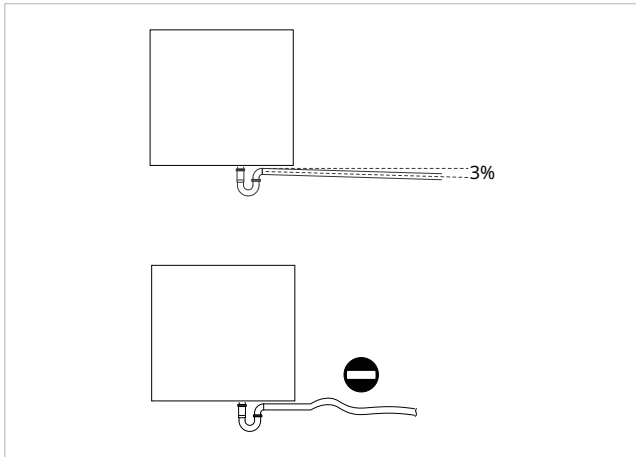

- ▶ connect the drain pipe to the drain connection with siphon
- ▶ direct the drainage pipe to a suitable place for draining

- ▶ maintain a minimum slope of 3% towards the drain location
- ▶ insulate junction points
- ⚠ **It is mandatory to install an adequate siphon on the condensate drainage pipe to prevent the negative pressure generated by the fans from obstructing the proper flow of condensate, which could lead to spillage inside the premises.**
- ⚠ Use plastic drainage pipes.
- ⚠ Avoid metal pipes.
- ⚠ Make sure all joints are sealed to prevent leakage of water.
- ⚠ Condensate drain pipes must be insulated for both indoor and outdoor sections to avoid condensation on the surface and/or frosting problems. The insulation must be inserted all the way to the condensate drain pipe connection on the unit.

3.12 Aeraulic connections

Preliminary warnings

- ⚠ The sizing of ducting and supply and extract grilles must be carried out by a professionally qualified person.
- ⚠ To prevent the transmission of any vibrations of the machine into the room, an anti-vibration joint should be placed between the fan outlets and the ducts.

- ⚠ The connecting pipes must be of a suitable diameter and supported so that their weight does not put strain on the appliance.

Airflow configurations

- A factory configuration
- B configuration modifiable on site

Configuration A Horizontal installation

RIP: Extract air
IMM: Supply air
EXP: Exhaust air
PAE: Fresh air inlet

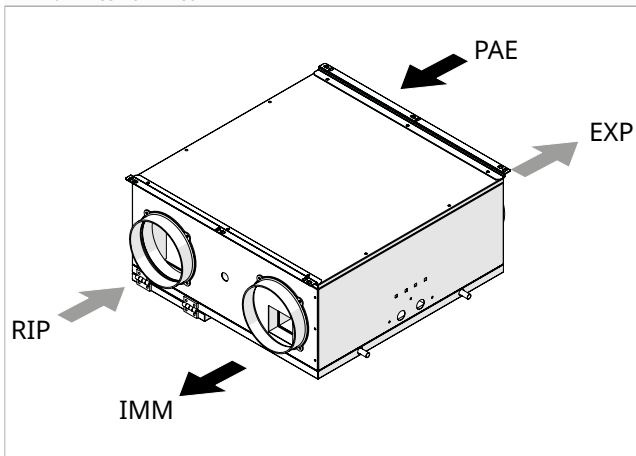

Configuration B Horizontal installation

RIP: Extract air
IMM: Supply air
EXP: Exhaust air
PAE: Fresh air inlet

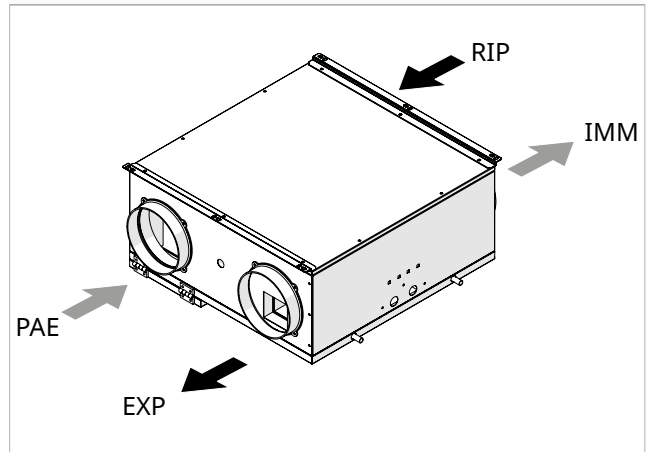

Configuration A Vertical installation

- RIP:** Extract air
- IMM:** Supply air
- EXP:** Exhaust air
- PAE:** Fresh air inlet

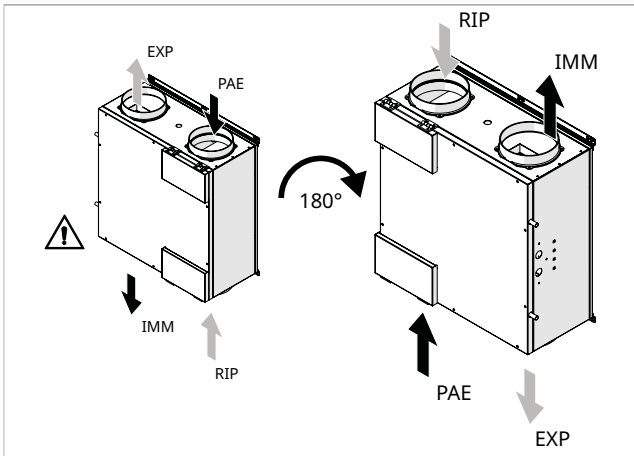

Configuration B Vertical installation

- RIP:** Extract air
- IMM:** Supply air
- EXP:** Exhaust air
- PAE:** Fresh air inlet

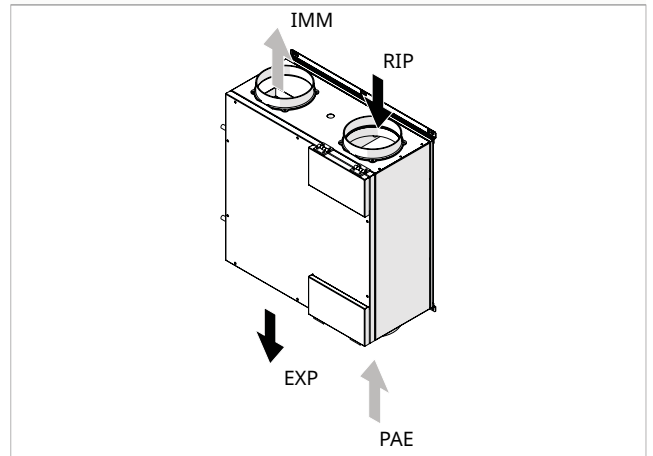

⚠ To install the vertical A configuration on the wall it is necessary to rotate the unit 180°.

Changing the airflow configuration from A to B

To modify the configuration, switch microswitch E from Off to On. The unit will automatically reverse the fan outputs,

the probe properties, and the respective anti-freeze and bypass control logics.

1. Microswitch E

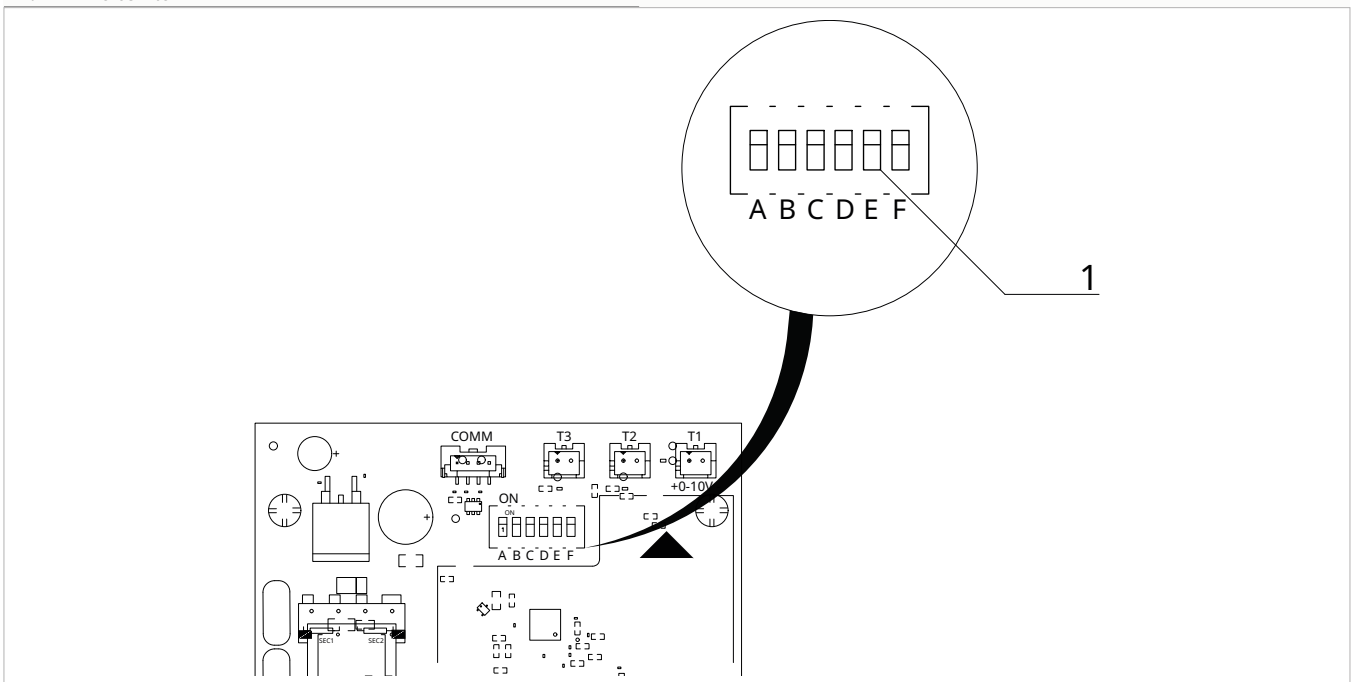

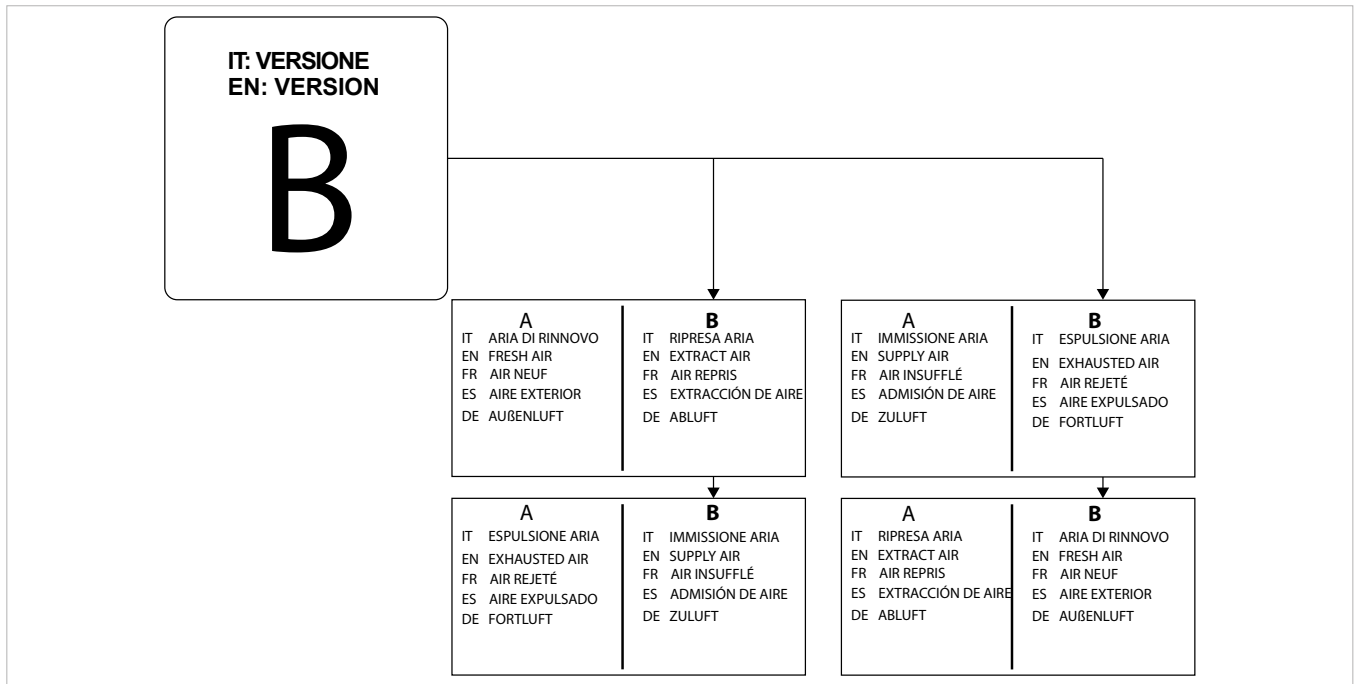

Label application:

To indicate that the machine configuration has been changed, the supplied label must be applied. The presence of the label indicates that you must refer to column B in the airflow labels.

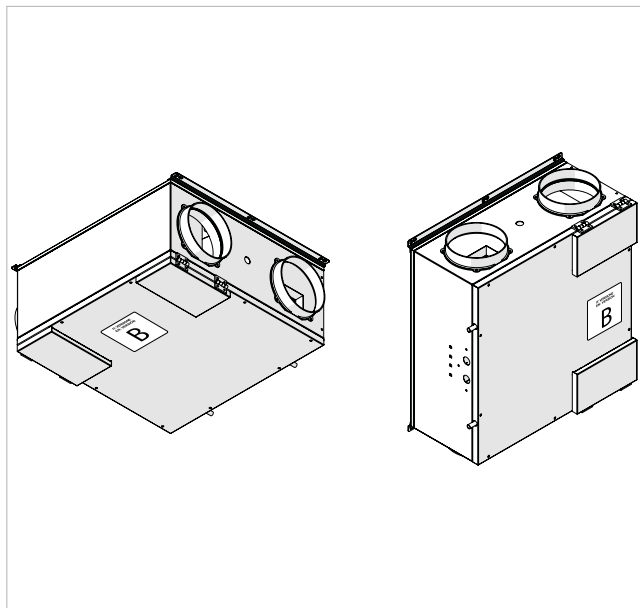

- ▶ Horizontal installation: apply the label to the lower panel
- ▶ Vertical installation: apply the label on the front panel

Connections

Room side

Configuration A

1. Room side air intake
2. Supply

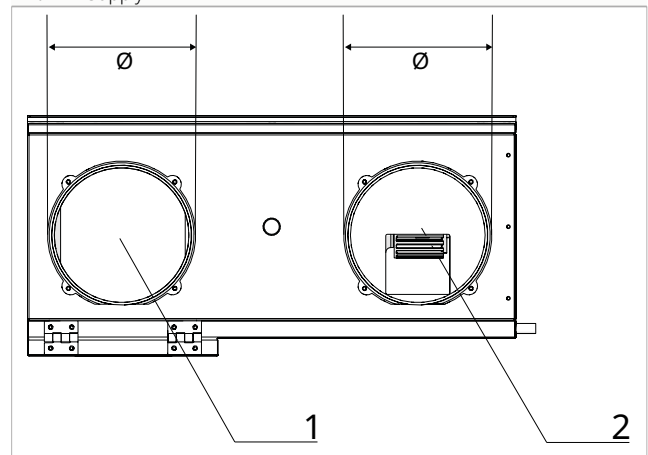

Models	u.m.	08	10	15	20	25
Room side air connection	mm	125	160	160	160	160

Outdoor side**Configuration A**

1. Expulsion
2. Outdoor air

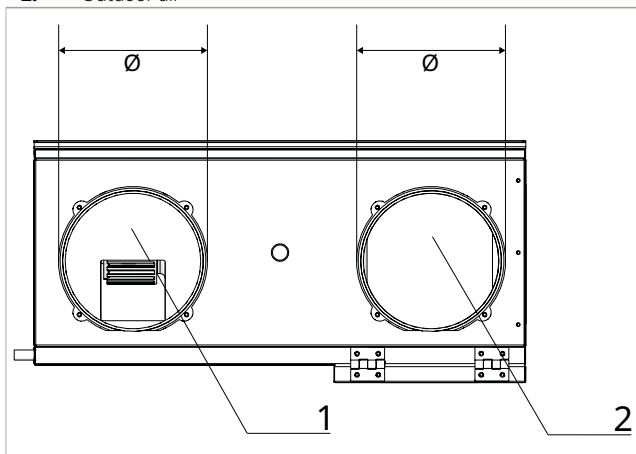

Models	u.m.	08	10	15	20	25
Outdoor side air connection	mm	125	160	160	160	160

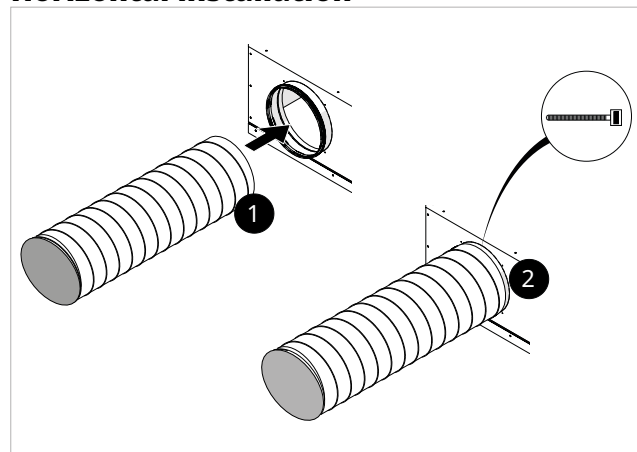
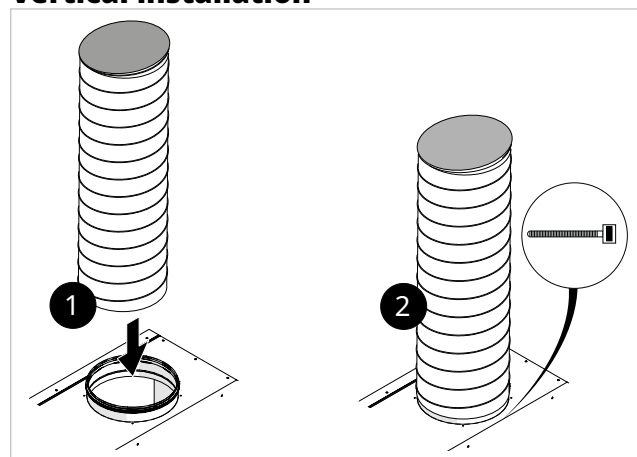
Circular connections**Horizontal installation****Vertical installation**

- ▶ position the ducts on the connections provided on the appliance
- ▶ use a metal clamp or duct fixing collar
- ▶ fix the ducts on the attachments
- ⚠ Use ducts lined with anti-condensation material of a suitable thickness.

3.13 Electrical connections

The appliance leaves the factory fully wired and only requires connection to the power supply, control and any accessories.

Preliminary warnings

- ⚠ All operations of an electrical nature must be carried out by suitably qualified personnel having the necessary legal knowledge and informed about the risks related to such operations.
- ⚠ All connections must be made in accordance with the relevant regulations in force in the country of installation.
- ⚠ Before carrying out any work, make sure that the power supply is switched off.
- ⚠ The unit should only be powered after the plumbing and electrical work has been completed.

⚠ References:

- for electrical connections please refer to the wiring diagrams in this manual, especially for the part concerning the power terminal board

⚠ Check that:

- the main supply characteristics are adequate for the power consumption of the appliance, also taking into account any other machinery in parallel operation
- the power supply voltage and frequency correspond to those specified on the nameplate of the appliance
- the cables are suitable for installation in accordance with the IEC standards in force
- the power supply is adequately protected against overloads and/or short circuits

- the disconnection device is positioned in an easily accessible place to enable intervention in the event of an emergency
- ⚠ It is mandatory:
- to connect the appliance to an effective grounding system
- for units with three-phase power supply, check the correct phase connection
- provide an all-pole switch with a contact opening distance of at least 3 mm that allows complete disconnection under overvoltage category III conditions
- Install a ground fault circuit interrupter (GFCI). Failure to install this device could result in electric shock
- ⚠ Ensure that a connection to earth is made. Do not ground the appliance to distribution pipes, surge arresters or the ground of telephony systems. If not performed correctly, grounding can cause an electric shock. Momentary high voltage surges caused by lightning or other causes could damage the heat pump.
- ⚠ Use a dedicated power supply circuit. Never use a power supply to which another appliance is also connected due to risk of overheating, electric shock or fire.
- ⚠ For the electrical connection, use a cable of sufficient length to cover the entire distance without any connection. Do not use extension cables. Do not apply other loads on the power supply.
- ⚠ After connecting the interconnection and power supply cables, ensure that the cables are arranged so that they do not exert excessive forces on the covers or electrical panels. Install the covers on the cables. Incomplete connections of the covers can lead to overheating of the terminals, electric shock or fire.
- ⚠ Any replacement of the power cable must only be carried out by qualified personnel and in accordance with current national regulations.
- ⚠ The manufacturer is not liable for any damage caused by the lack of earthing or failure to comply with the specifications in the respective diagrams.
- ⚠ The appliance is equipped with a noise filter as required by current regulations. Use selective residual current circuit breakers to compensate for the micro leakage to earth of this device.
- ⊖ Using gas and water pipes to ground the appliance is prohibited.

Power line dimensioning

Use the tables below for the sizing of the power supply line and its protection device.

These are not average draw or transient peaks, but values to be considered for the correct sizing of the plant and the request of the contractual power (excluding loads due to the normal operation of the building).

- ⚠ Maximum power is reached only in exceptional cases. Therefore, the indicated trip current is suggested to guarantee a balance between machine absorption and incidence in the general system.
- ⚠ The indicated minimum cable cross-section area must be verified according to the actual conditions of the installation: length of the cable, characteristics of the electrical supply, etc.
- ⚠ For units equipped with electrical heating elements, the draw values of the units must be added to those of the heating elements shown in the following tables.

Access to the electrical panel

- ⚠ Access to the electrical panel is only permitted to qualified personnel.
- ⚠ Before carrying out any work, ensure that the power supply is switched off.

Horizontal installation

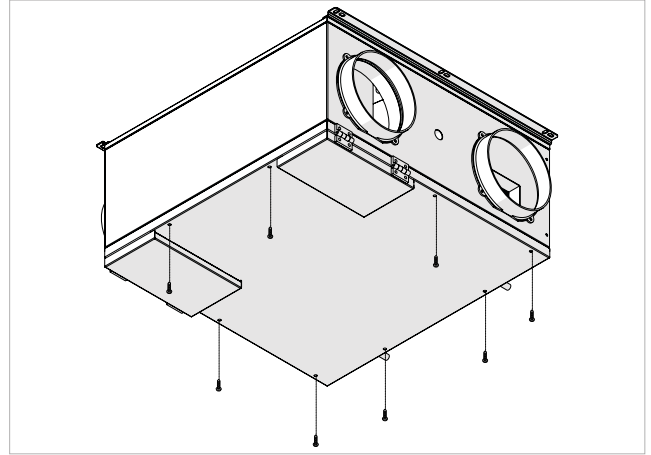

Horizontal installation

1. Electrical panel

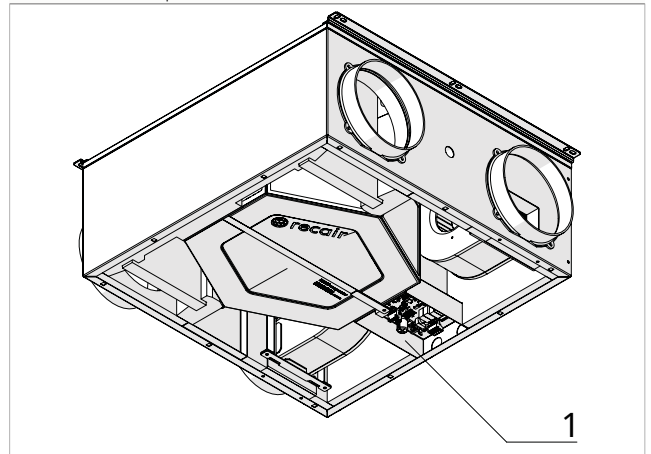

Vertical installation

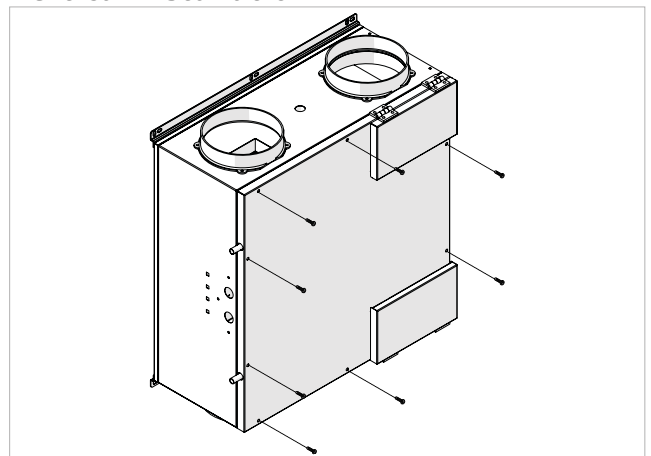

Vertical installation

1. Electrical panel

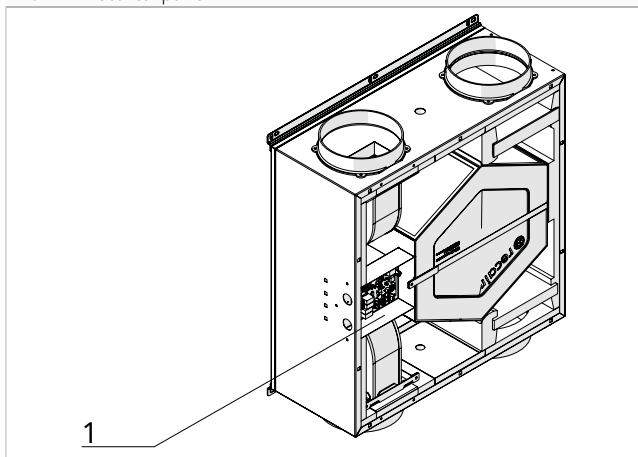

To access the connections:

- ▶ undo the fixing screws
- ▶ remove the lower panel

Connections

Before connecting the unit to the mains power supply, make sure that the isolator is open. The power supply of the single-phase unit must be connected to the appropriate terminals, subjected to the action of the isolating switch.

⚠ Use properly sized cables to avoid voltage drops or overheating.

Connection diagram

1. 230/1/50 power supply
2. Isolator
3. Power cable

4. Unit
5. Remote control
6. Wired controller communication cable

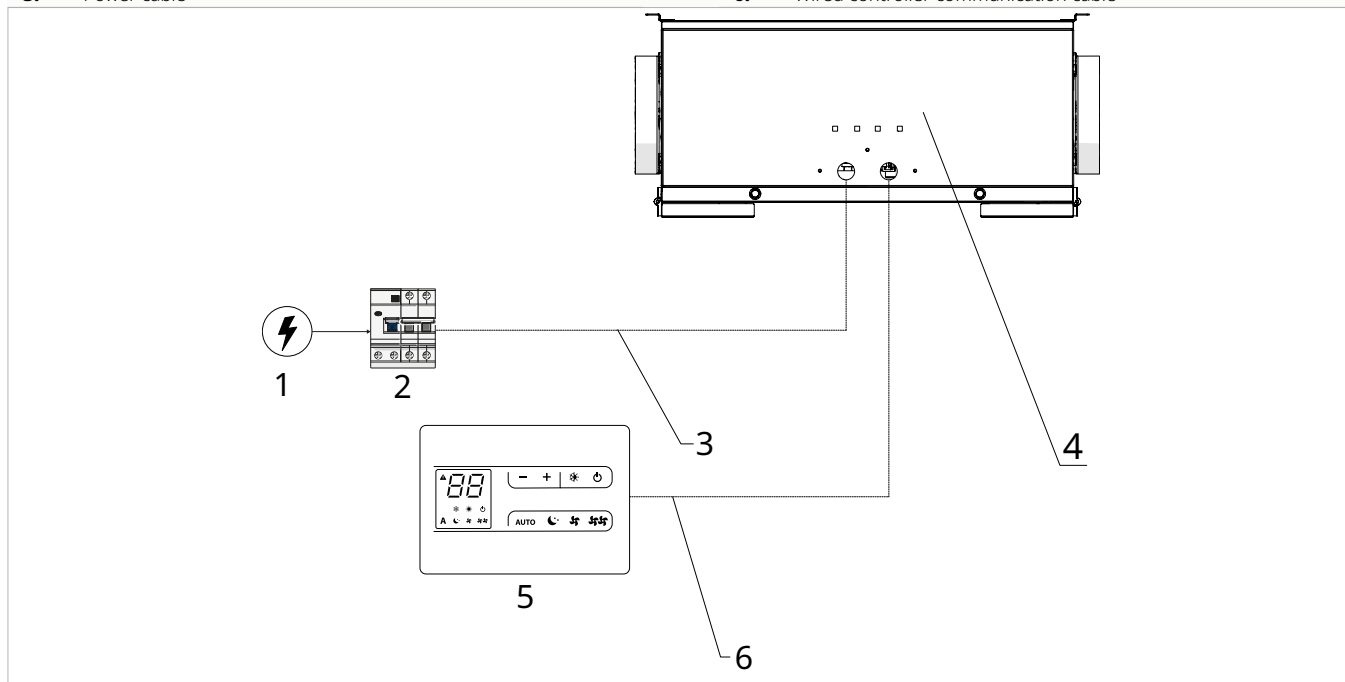

4. REMOTE CONTROL

4.1 Installation

Description

The control panel is an electronic controller with humidity and air quality sensors inside, with the possibility of control over several devices equipped with the same circuit board. It is equipped with a humidity and air quality sensor.

⚠ The temperature probe can be remote-controlled in one of the connected units.

Mounting

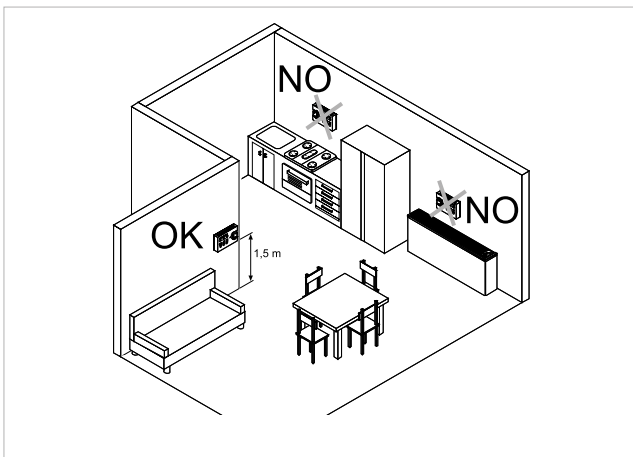

The control panel must be installed:

- on the outside walls
- at a height of approx. 1.5 m above the floor
- away from doors and windows
- away from heat sources such as radiators, fan coils, cookers, direct sunlight

⚠ The control panel is supplied in the package already assembled.

A Notches

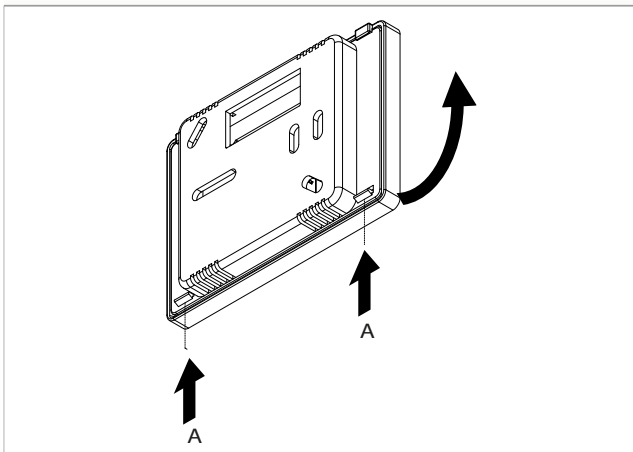

Before mounting on the wall:

- ▶ release the fastening notches on the rear side of the control panel
- ▶ separate the base from the control panel
- ▶ use the base as a template to mark out the fixing points

A	Control base
B	Holes for fixing to the wall
C	Screws
D	Hole for the passage of electrical connections

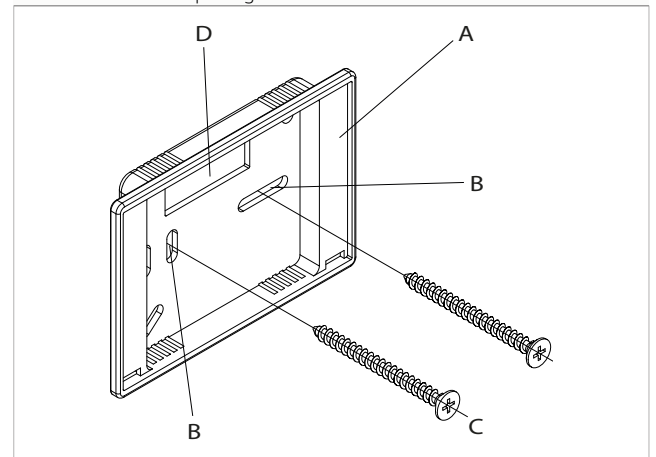

For wall mounting of the control panel:

- ▶ drill holes in the wall
 - ▶ pass the electrical cables through the prepared hole
 - ▶ fix the base of the control unit to the wall using suitable screws and dowels
 - ▶ make electrical connections
 - ▶ close the control panel
- ⚠ Take care not to crush the wires when closing the control panel.

4.2 Electrical connections

Connection diagram

Unit I version

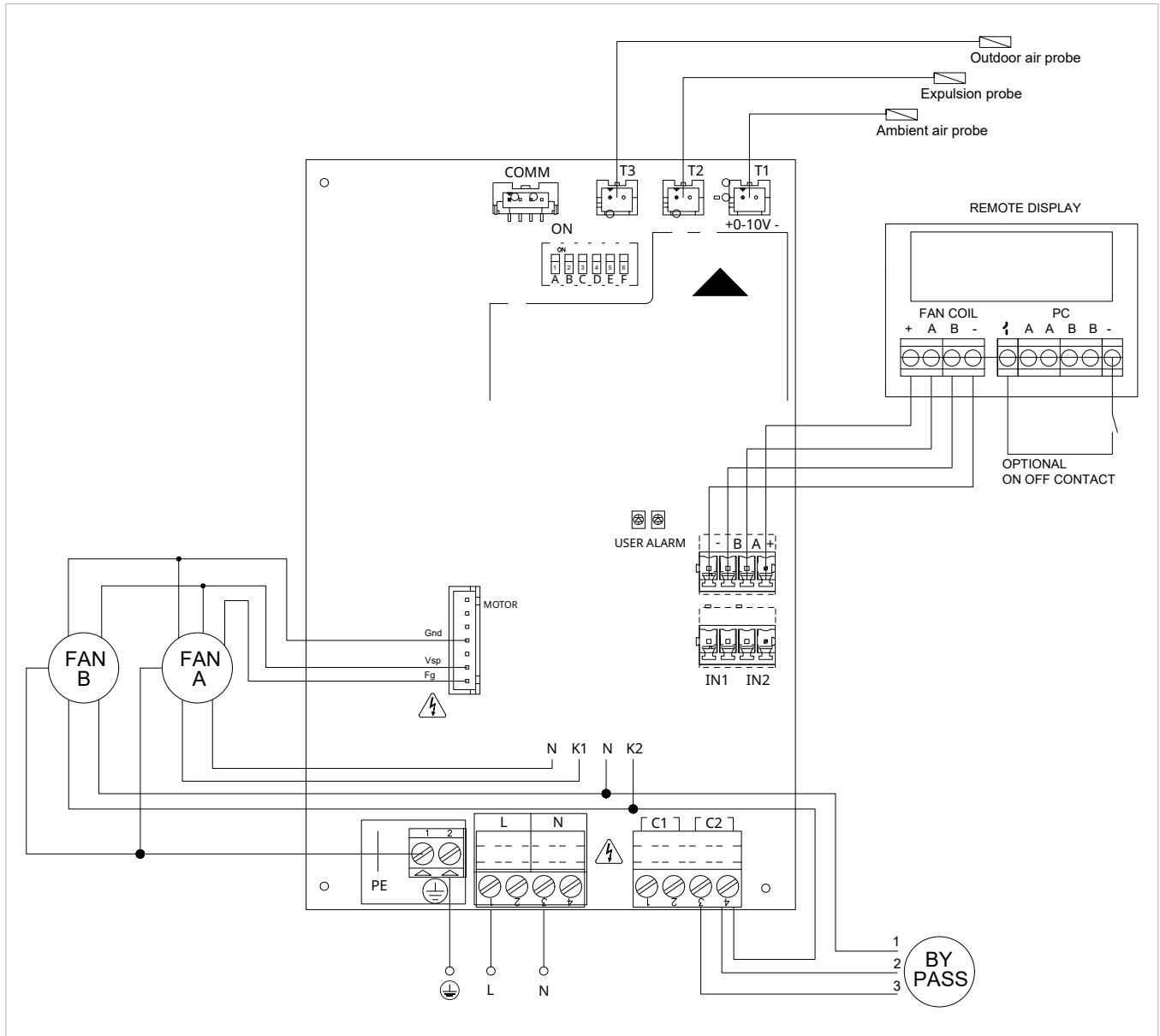

Connections to be made by the customer

L - PE - N	Unit power supply	230 / 1 / 50
IN1	Booster speed (standard) / Dirty filters input (configurable)	Contact closed / function active
C1	Generator control / Water valve / Post-heating battery / Pre-heating battery	Free contact
C2	Bypass	Voltage contact 220V
Remote display	Remote control (wired)	
Remote On - Off (on display)	On - Off remote contact on remote display	Contact closed / unit off

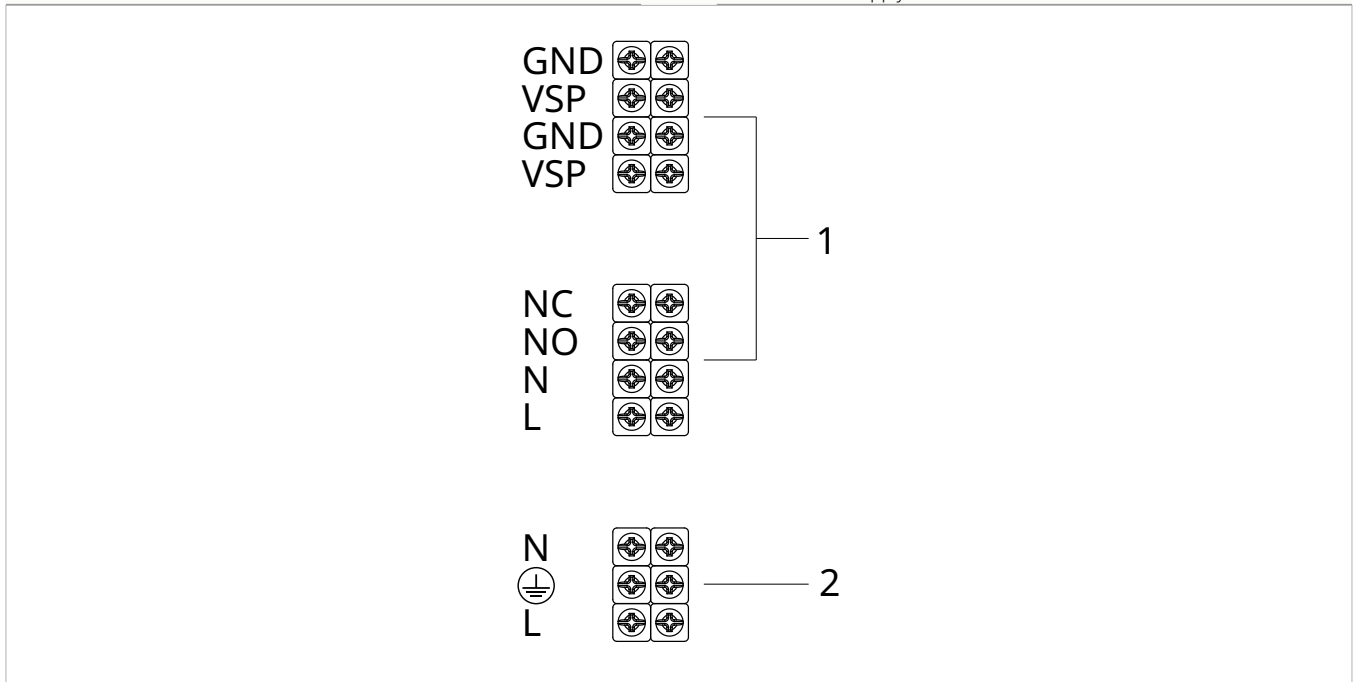
Unit S version**1.** Remote control**2.** Power supply**Connections to be made by the customer**

L - PE - N	Unit power supply	230 / 1 / 50
L N	Control panel power supply	230 / 1 / 50
NO / NC	Bypass command	Voltage contact (220 V)
VSP / GND	Signal to the fans	VSP / GND (0 - 10 vdc signal)

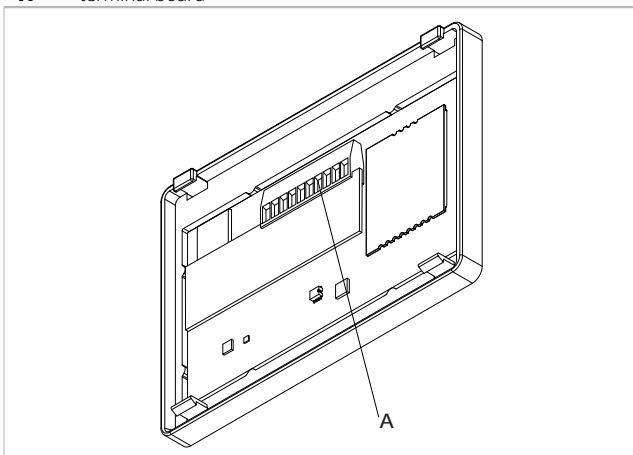
Terminal board position**A** terminal board

The terminals allow the connection of rigid or flexible cables with cross-sections of 0.2 to 1 mm². For cables equipped with a cable lug with plastic collar the maximum cross-section is reduced to 0.75 mm².

Connection to circuit board

For the connection:

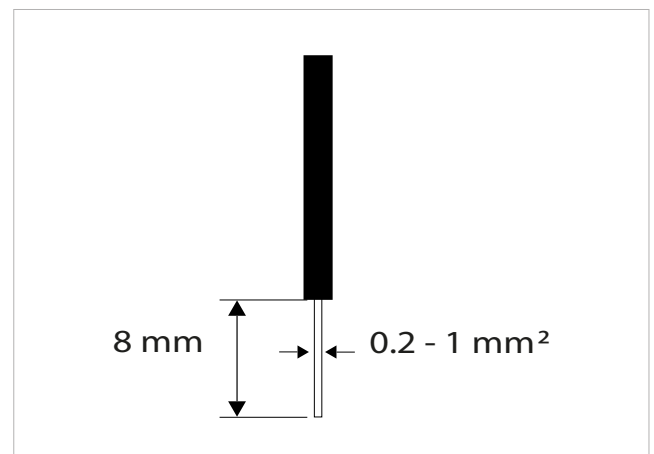

- ▶ remove a portion of the insulation from the cable end
- ▶ insert the cable into the terminal
- ▶ screw tightly
- ▶ check for correct attachment by lightly pulling on the cable
- ⚠ The cable must be shielded twisted 4 x 0.75 mm², maximum length 50 m.

On - Off remote connection

Through this contact it is possible to connect an external device which inhibits the operation of the appliance, such as:

- remote on/off (on display)

Operation

When the contact connected to the PC input is closed, all units are switched off.

When a button is pressed on the display, the symbol  flashes

- It is forbidden to connect the PC input in parallel with other electronic boards. In this case, use separate contacts.

RS485 serial connection

The control panel can be connected via an RS485 line to one or more units directly to the control board on the unit or via the remote displays.

For the connection:

- ▶ respect the indications "A" and "B"
- ▶ connect appliances in series
- ⚠ Use a shielded two-core cable suitable for serial RS485 connection with a minimum cross-section of 0.35 mm².
- ⚠ Keep the two-core cable separate from the power supply cables.
- ⚠ Route in such a way as to minimise the length of deviations.
- ⚠ Terminate the line with a 120 Ω resistor.
- "Star" (y) connections are prohibited.

4.3 Interface

Description

The control panel is an electronic controller with humidity and air quality sensors inside. It has the possibility of operating several units equipped with the same circuit board.

Features:





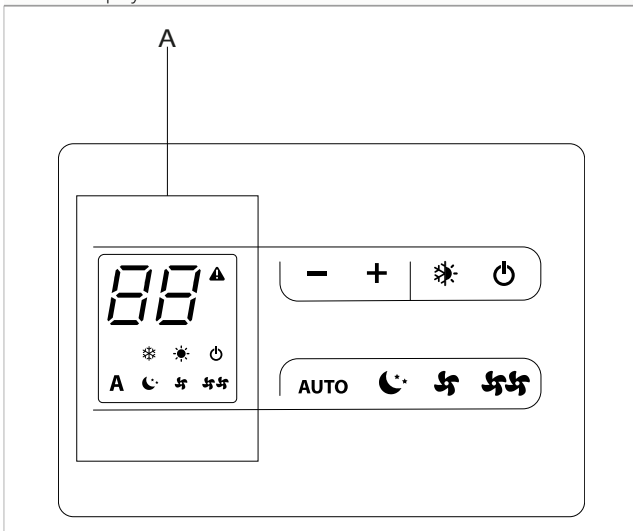

- unit's stale air intake probe reading
- internal memory with data storage even in the event of abnormal shutdown or power failure
- ⚠ The room temperature probe provides frost protection even when the control panel is in stand-by mode.
- ⚠ The brightness of the control panel is reduced 20 seconds after the last action, the display only shows the room temperature. Pressing any button restores maximum brightness.
- ⚠ Refer to the User's Manual for operation on the control panel.

Display

A Display area



Status and alarms shown on the display.



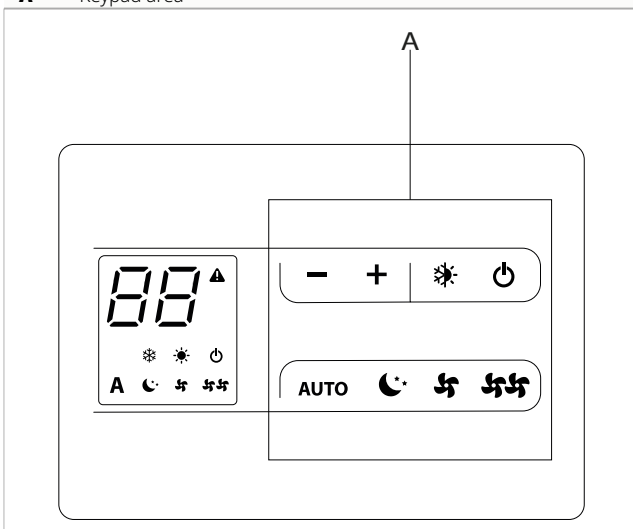

-  Alarm indication
Flashing with closed CP contact
Lit for alarm indication
-  Summer mode active
-  Winter mode active
-  Unit in stand-by
- A** Auto function
-  Minimum ventilation speed activated
-  Rated ventilation speed activated
-  Maximum ventilation speed activated

Keypad key functions

A Keypad area





Related keys and functions



- Decreases the set temperature
- +** Increases the set temperature
-  Allows you to change the operating mode between summer and winter
-  Allows the control panel to be switched on or put into stand-by mode
- AUTO** Makes ventilation speed adjustment fully automatic according to IAQ values is RH %
-  Allows you to set the minimum ventilation speed
-  Allows you to set the rated ventilation speed / Allows you to set the desired humidity value
-  Allows you to set the maximum ventilation speed

General switch-on

Before switching on:

-  Make sure that the control panel is connected to the power supply.
-  If there is a main switch on the power supply line, switch the system on by pressing the switch.

To activate the device

- ▶ press and hold the button 
The symbol  lights up

4.4 Warnings

Throughout all seasons of the year, the system continuously monitors the air quality index. The sensor operates across different ranges:

- 0 to 1.99: Excellent air quality
- 2 to 2.99: Good air quality
- 3 to 3.99: Moderate air quality; it is recommended to limit exposure to these values to no more than 12 months
- 4 to 4.99: Poor air quality; exposure to these values is not recommended for more than 1 month
- 5: Unacceptable air quality; exposure to these values is not recommended.

⚠ The default setting value is 2.5. Changing this parameter is only possible through the installer menu, accessible only by authorized personnel.

Switching off for extended periods

In case of seasonal or long-term shutdown:

- ▶ deactivating the device
- ▶ set the system's main switch to off
- ⚠ The anti-freezing function is deactivated.

Error indication

- ⚠ **E1** Fault in the room temperature sensor located in the thermostat
- ⚠ **E2** Fault or connection of a double remote room sensor on one of the connected appliances
- ⚠ **E3** Temperature/humidity sensor not working
- ⚠ **E4** Air quality sensor not working

Error display

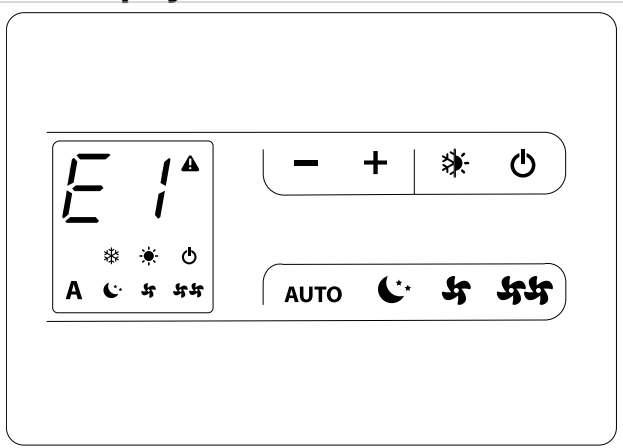

Filters alarm

- ▶ the symbol ⚠ flashes on the screen
- ▶ the filters have reached the operating time limit

To fix

- ▶ replace filters
- ▶ reset the panel

To replace filters

- ▶ refer to chapter "Cleaning or filter replacement" p. 36

To reset the panel

- ▶ press and hold the button for 5 seconds

Filter alarm display

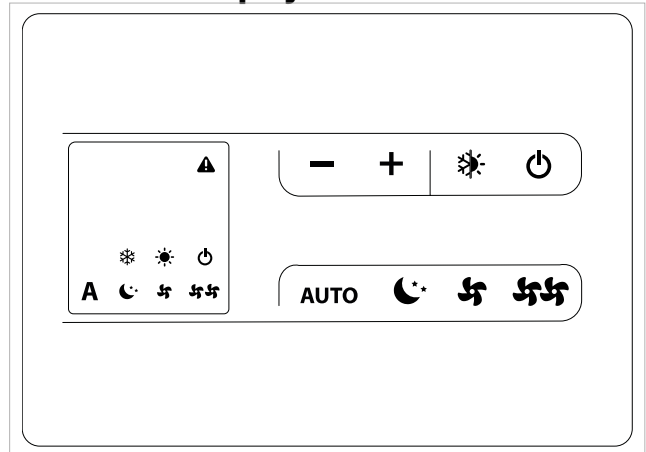

Air quality index

Throughout all seasons of the year, the system continuously monitors the air quality index.

The sensor operates across different ranges:

- 0 to 1.99: Excellent air quality
- 2 to 2.99: Good air quality
- 3 to 3.99: Moderate air quality; it is recommended to limit exposure to these values to no more than 12 months
- 4 to 4.99: Poor air quality; exposure to these values is not recommended for more than 1 month
- 5: Unacceptable air quality; exposure to these values is not recommended

⚠ The default setting value is 2.5. Changing this parameter is only possible through the installer menu, accessible only by authorized personnel.

5. START-UP

5.1 Preliminary warnings

- ⚠ **This section is dedicated to the Authorised Service Centre. The specifications of the Authorised Service Centre are described in chapter "Recipients" p. 4.**
- ⚠ **Initial commissioning must be carried out by the Authorised Service Centre.**
- ⚠ **For detailed information on accessories, refer to the relevant instruction sheets.**

See chapter "Compatible accessories" p. 10

- ⚠ The customer must be present when the appliance is tested and informed of the contents of the manual and procedures. After commissioning, the manual and the warranty certificate must be handed over to the customer.
- ⚠ Before start-up, all works (electrical, hydraulic and air-flow connections) must have been completed.

5.2 First start-up

Preliminary Checks

Before commissioning, check that:

Operational checks

- all safety conditions have been met
- the unit has been properly secured to the supporting surface or wall
- the minimum technical spaces have been observed

Airflows

- the airflow connections have been made according to the instructions in the manual
- all airflow connections are correctly secured
- the ducting is correctly supported
- the ducting does not have any bottlenecks
- the ducting is thermally insulated

Electrical checks

- the cross-section of the power supply cables is adequate for the absorption of the appliance and the length of the connection made
- grounding is correctly performed
- the electrical connections have been established correctly
- all control wires are connected and that all electrical connections are secure

Settings

Microswitches

There are microswitches on the board for the various operating configurations of the unit. It is essential to set the microswitches correctly; the table shows the various operating modes.

- | | |
|----|---------------|
| 1. | Microswitch A |
| 2. | Microswitch B |
| 3. | Microswitch C |
| 4. | Microswitch D |
| 5. | Microswitch E |
| 6. | Microswitch F |

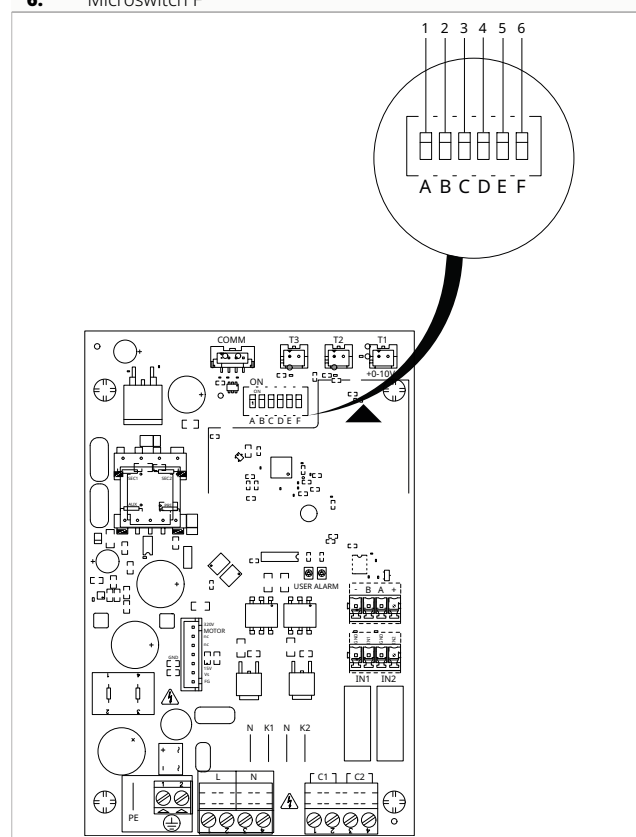

MICROSWITCH FUNCTIONS		
Microswitch A	ON	OFF
	Preheating coil activation contact CHILLER	Postheating coil activation contact CHILLER
Microswitch B	ON	OFF
	Enabling of unit with modulating coil control	Disabling of unit with modulating coil control
Microswitches C - D	ON OFF	OFF ON
	Room humidity control	Room air quality control
	ON ON	OFF OFF
	Humidity and room air quality control active. The maximum value of the two calculated values is used	Moisture and ambient air quality controls deactivated
Microswitch E	ON	OFF
	Configuration B	Configuration A (standard)
Microswitch F	ON	OFF
	RTU	ASCII (standard)

- ⚠ Microswitch A Management of pre-heating and post-heating batteries. Verify the connections.
- ⚠ Microswitch B The unit model is set to OFF by default. Do not change the setting to prevent the unit from malfunctioning.
- ⚠ Microswitches C - D The combination of these microswitches decides the operation of the humidity and air quality sensors.
- ⚠ Microswitch E The unit model is factory-set to OFF. If set to ON, please verify the connections and the application of label B.
- ⚠ Microswitch F The unit model is factory-set to OFF. If set to ON, the control panel will cease to respond.
- ⓘ **In case of installation of the electric heating battery accessory, refer to the section "Accessories" p. 61 for the setting of the microswitches.**

Start-up

After all checks have been carried out, the unit can be put into operation.

To activate the appliance:

- ▶ refer to the user manual

Checks with the machine switched on

After starting up, check that

Operational checks:

- verify the different modes of operation
- verify that the appliance stops and then restarts

- switch the appliance off and on again and check that it restarts correctly
- the appliance operates within the recommended operating conditions (see technical specifications table)
- check that the air flow rates are correct
- verify that the unit's configuration complies with the site requirements

Hydraulic Checks

- check for proper condensate drainage

Electrical Checks

- the current absorbed is less than the maximum indicated in the technical data table
- the supply voltage value is within the set limits and does not fall below the nominal value -10 % during operation

5.3 Plant delivery

Once all the checks and controls on the correct operation of the plant have been completed, the installer must explain the following to the user:

- the basic functional characteristics of the appliance
- the instructions for use
- the routine maintenance

5.4 Switching off for extended periods

If the appliance is not used for a long period of time, the following steps must be taken:

- ▶ deactivating the device
- ▶ isolate the power supply
- ⚠ To restart the appliance after it has been out of use for a long period, call in the Authorised Service Centre.

6. MAINTENANCE

6.1 Routine maintenance

Annual operations

The once-a-year maintenance plan includes the following operations and checks and must be carried out by the Authorised Service Centre or by qualified personnel.

Electrical circuit

Check:

- electrical supply voltage
- the electrical absorption
- tightening connections
- that there is no damage or excessive wear to electrical cables
- that the gaskets and sealing materials have not deteriorated to such an extent that they are no longer suitable for the purpose of preventing the development of flammable atmospheres inside
- the correct fixing of cable glands
- safety devices

Mechanical checks

Check:

- tightening of the screws, fans and electrical box, of the unit's external panelling
- the state of the structure
- ⚠ Bad fixings result in abnormal noise and vibration.
- ⚠ If oxidised parts are present, treat them with suitable paints to eliminate or reduce oxidation.

Hydraulic controls

Check:

- the regular drainage of condensate
- cleaning the condensate collection trays
- cleaning the exhaust ducts

Airflow controls

Check:

- the regular flow of air
- cleaning of any intake grilles
- cleaning the ducting

Cleaning

- cleaning of aesthetic cover
- cleaning or filter replacement
- cleaning the heat exchanger

Cleaning or filter replacement

Horizontal installation

1. Filter
2. Filter access hatch

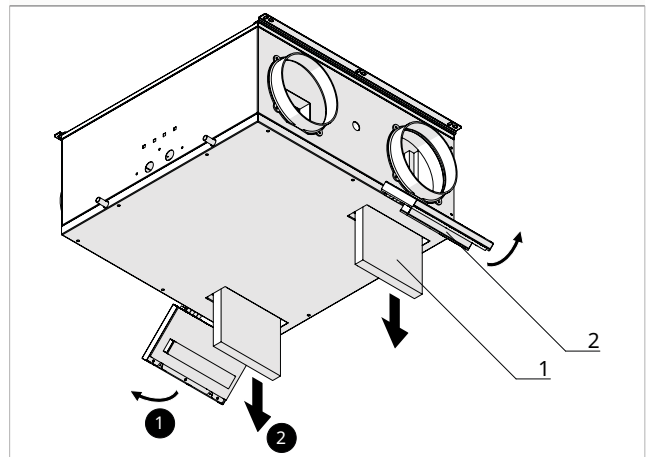

Vertical installation

1. Filter
2. Filter access hatch

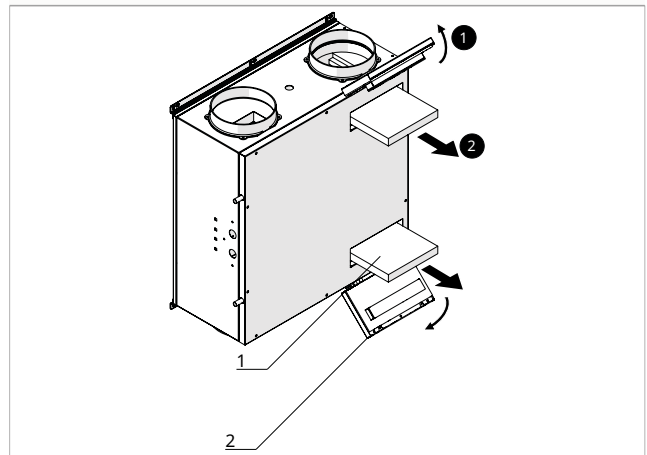

To remove:

- ▶ isolate the power supply to the unit
- ▶ open the filter access hatch
- ▶ take out the filter

⚠ Pay attention to sharp surfaces

ⓘ **If the condition of the filters is acceptable, they can be cleaned using a vacuum cleaner or a low-pressure compressor.**

ⓘ **If it is impossible to clean them, the filters must be replaced.**

To reposition:

► perform in reverse order

ⓘ To prevent dirt from entering the heat exchanger, clean in the opposite direction to the air flow.

Cleaning the heat exchanger

Cleaning the heat exchanger

Horizontal installation

1. Heat exchanger
2. Pack retainer
3. Lower panel

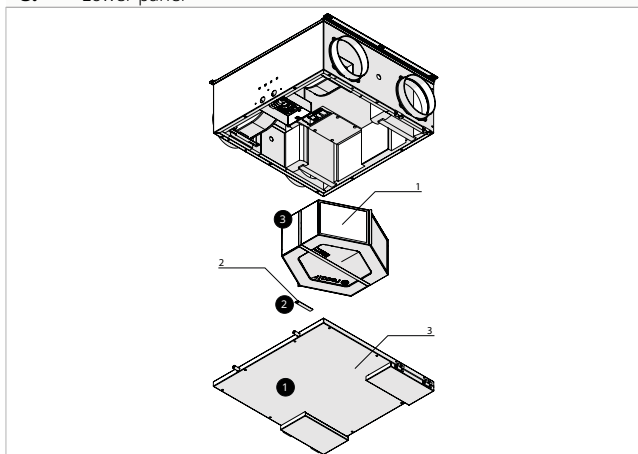

Vertical installation

1. Heat exchanger
2. Pack retainer
3. Lower panel

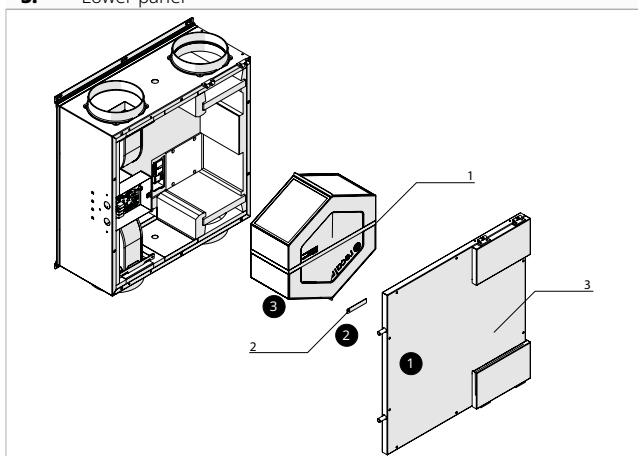

- isolate the power supply to the unit
 - disconnect the condensate drain pipe
 - remove the lower panel of the unit by releasing the fixing hooks and removing the screws
 - extract the heat exchanger
 - gently proceed with cleaning using a vacuum cleaner or a low-pressure compressor
 - reposition the heat exchanger
 - reposition the lower panel by locking it with the fixing hooks and inserting the screws
- ⚠ Never touch the fins of the heat exchanger, handle only the closed sides.
- ⓘ **There is a special clamp/green strap for removing the heat exchanger.**

7. FAULTS AND REMEDIES

7.1 Preliminary warnings

If one of the following faults is found:

- ventilation does not activate
- the appliance makes excessive noise
- there is dew formation on the front panel

Follow the instructions below:

- ▶ immediately isolate the power supply
- ▶ contact an Authorised Service Centre or professionally qualified personnel
- ⚠ The intervention must be carried out by a qualified installer or an Authorised Service Centre.
- ⊘ Personal intervention is prohibited.

7.2 Troubleshooting table

DESCRIPTION OF FAULT	CAUSE	REMEDY
The fans are not active	The power supply is not switched on	Check the fan power supply
	The fan speed regulation device does not work	Check fan speed regulation device
	Incorrect electrical connections	Check electrical connections.
	Fans in thermal protection	Check that the fan has not overheated and switched to thermal protection
Insufficient air flow or pressure	Clogged filters	Clean filters
	Insufficient rotation speed	Increase rotation speed
	Ducting or exchanger clogged	Clean ducting or heat exchanger
Insufficient heat exchanger efficiency	Exchanger fins clogged	Clean exchanger surfaces
Excessive vibration and noise	Incorrect installation of the unit	Check unit brackets and fastenings
	Incorrect ducting installation	Check brackets and duct fixings
	Fan impeller imbalance	Check fan impeller condition
Water leaks from unit	Clogged condensate drain	Clean condensate drain
	Siphon not installed correctly	Check the correct installation of the siphon
Difficult start-up	Supply voltage too low	Check that the supply voltage is not below 10% of the rated voltage

7.3 Alarm table and card flashes

DESCRIPTION OF ALARM	CAUSE	REMEDY	CARD FLASHES
Recovery ambient probe / External air alarm - T1	Sensor breakage or failure to read	Check probe connection or replace sensor	1 flash - off 3 seconds
Fan alarm	Fan connector faulty or feedback signal absent	Check the connection of the fan connector to the board	2 flashes - off 3 seconds
		Replace fan control cable Filters alarm counter reached Replace filters and reset	
Filters alarm	counter reached	Replace filters and reset	
Expulsion / intake probe alarm - T2	Sensor breakage or failure to read	Check probe connection or replace sensor	3 flashes - off 3 seconds
Outdoor air / extracted air probe alarm - T3	Sensor breakage or failure to read	Check probe connection or replace sensor	5 flashes - off 3 seconds
Remote display connection alarm	Remote display connection error	Check electrical connections.	LED off
		Check that A and B are not reversed	
		Check the correct insertion of the display connection board on the main board	
Remote display communication alarm	No communication between display and board for at least 300 seconds	Check the filter status and press and hold the On - Off button to reset the signalling	6 flashes - off 3 seconds
		Check that A and B are not reversed	
		Check the correct insertion of the display connection board on the main board	

8. TECHNICAL INFORMATION

8.1 Technical data

Models	u.m.	08-Z	10-Z	15-Z	20-Z	25-Z
VMC airflow performance						
Nominal air flow rate	m ³ /h	110	130	210	200	320
Available pressure	Pa	100	100	100	100	100
Heat recovery performance (A 7; A 20) (1)						
Sensible recovery efficiency	%	89,0	87,0	85,0	87,0	85,0
Room side fan						
Type		Centrifugal - directly coupled electronic motor				
Number	No.	1	1	1	1	1
Outdoor side fan						
Type		Centrifugal - directly coupled electronic motor				
Number	No.	1	1	1	1	1
Heat exchanger						
Type		Polypropylene countercurrent plates				
Number	No.	1	1	1	1	1
Fresh air filter						
Type		Pleated flat filter				
Number	No.	1	1	1	1	1
Efficiency		ePM1 80%				
Extract air filter						
Type		Pleated flat filter				
Number	No.	1	1	1	1	1
Efficiency		ePM1 80%				
Room side sound levels (UNI EN 3741; 3744) (2)						
Sound power transmitted to the Lw structure	dB (A)	49,0	48,0	51,0	48,0	52,0
Sound power radiated in the Lw channel	dB (A)	53,0	55,0	57,0	55,0	60,0
Average sound pressure at 1 m Lp	dB(A)	42,0	41,0	43,0	41,0	45,0
Average sound pressure at 3 m Lp	dB(A)	34,0	34,0	36,0	34,0	38,0
Electrical characteristics						
Power supply	V / ph / Hz	230 / 1 / 50				
Maximum total absorbed power	kW	41,00	80,00	140,00	120,00	180,00
Maximum total absorbed current	A	0,35	1,20	1,20	2,20	2,20
Protection rating	IP	X2				
1. Efficiency according to UNI EN 13141-7 Outdoor temperature 7 °C - Outdoor humidity 72 % - Indoor temperature 20 °C - Indoor humidity 28 %. 2. Data refers to the UNI EN 3741 and UNI EN 3744 standards 3. Without cover						

Models	u.m.	08-Z	10-Z	15-Z	20-Z	25-Z
Product dimensions						
Width	mm	580 (3)	580	580	580	580
Length	mm	580 (3)	580	580	580	580
Height	mm	190 (3)	276	276	315	315
Weight	kg	15,0 (3)	19,0	19,0	21,0	21,0
Connections						
Condensate drain connection	mm	12	12 / 20	12 / 20	12 / 20	12 / 20
Room side air connection	mm	125	160	160	160	160
Outdoor side air connection	mm	125	160	160	160	160
1. Efficiency according to UNI EN 13141-7 Outdoor temperature 7 °C - Outdoor humidity 72 % - Indoor temperature 20 °C - Indoor humidity 28 %. 2. Data refers to the UNI EN 3741 and UNI EN 3744 standards 3. Without cover						

Models	u.m.	08-ZX	10-ZX	15-ZX	20-ZX	25-ZX
VMC airflow performance						
Nominal air flow rate	m ³ /h	110	120	160	180	245
Available pressure	Pa	100	100	100	100	100
Heat recovery performance (A 7; A 20) (1)						
Sensible recovery efficiency	%	89,0	80,0	75,0	78,0	76,0
Enthalpy recovery efficiency	%	56,0	65,0	63,0	64,0	62,0
Room side fan						
Type		Centrifugal - directly coupled electronic motor				
Number	No.	1	1	1	1	1
Outdoor side fan						
Type		Centrifugal - directly coupled electronic motor				
Number	No.	1	1	1	1	1
Heat exchanger						
Type		Polypropylene countercurrent plates				
Number	No.	1	1	1	1	1
Fresh air filter						
Type		Pleated flat filter				
Number	No.	1	1	1	1	1
Efficiency		ePM1 80%				
Extract air filter						
Type		Pleated flat filter				
Number	No.	1	1	1	1	1
Efficiency		ePM1 80%				
Room side sound levels (UNI EN 3741; 3744) (2)						
Sound power transmitted to the Lw structure	dB (A)	49,0	48,0	50,0	48,0	50,0
Sound power radiated in the Lw channel	dB (A)	53,0	55,0	57,0	55,0	59,0
Average sound pressure at 1 m Lp	dB(A)	42,0	41,0	43,0	41,0	45,0
Average sound pressure at 3 m Lp	dB(A)	34,0	34,0	36,0	34,0	38,0
Electrical characteristics						
Power supply	V / ph / Hz	230 / 1 / 50				
Maximum total absorbed power	kW	41,00	80,00	140,00	120,00	180,00
Maximum total absorbed current	A	0,35	1,20	1,20	2,20	2,20
Protection rating	IP	X2				
Product dimensions						
Width	mm	580 (3)	580	580	580	580
Length	mm	580 (3)	580	580	580	580
Height	mm	190 (3)	276	276	315	315
Weight	kg	15,5 (3)	21,0	21,0	21,5	21,5
Connections						
1. Efficiency according to UNI EN 13141-7 Outdoor temperature 7 °C - Outdoor humidity 72 % - Indoor temperature 20 °C - Indoor humidity 28 %.						
2. Data refers to the UNI EN 3741 and UNI EN 3744 standards						
3. Without cover						

Models		u.m.	08-ZX	10-ZX	15-ZX	20-ZX	25-ZX
Room side air connection		mm	125	160	160	160	160
Outdoor side air connection		mm	125	160	160	160	160
Condensate drain connection		mm	12	12 / 20	12 / 20	12 / 20	12 / 20
1. Efficiency according to UNI EN 13141-7 Outdoor temperature 7 °C - Outdoor humidity 72 % - Indoor temperature 20 °C - Indoor humidity 28 %. 2. Data refers to the UNI EN 3741 and UNI EN 3744 standards 3. Without cover							

8.2 Operating limits

Sensible version winter operating limits

A Indoor temperature
B Outdoor temperature

C Preheating requirement zone

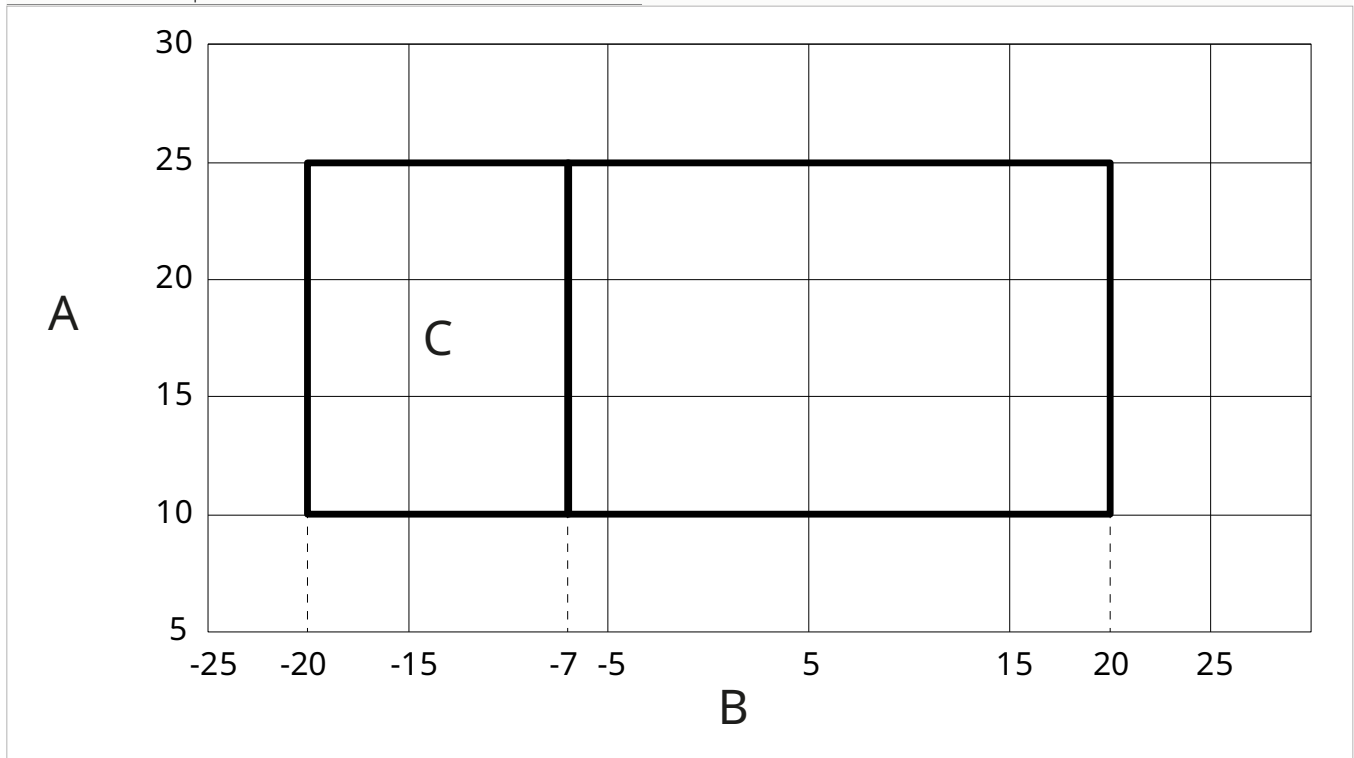

Sensible version summer operating limits

A Indoor temperature

B Outdoor temperature

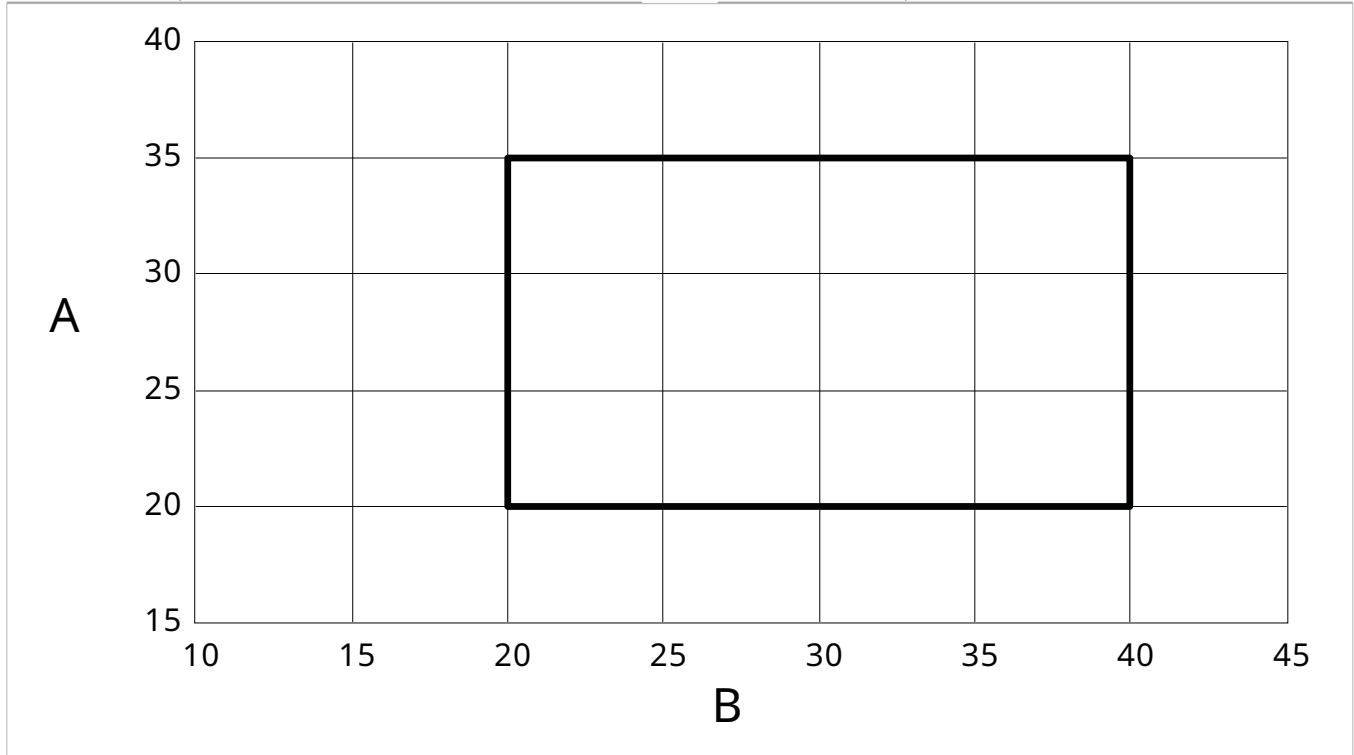

Enthalpy version winter operating limits

A Indoor temperature
B Outdoor temperature

C Preheating requirement zone

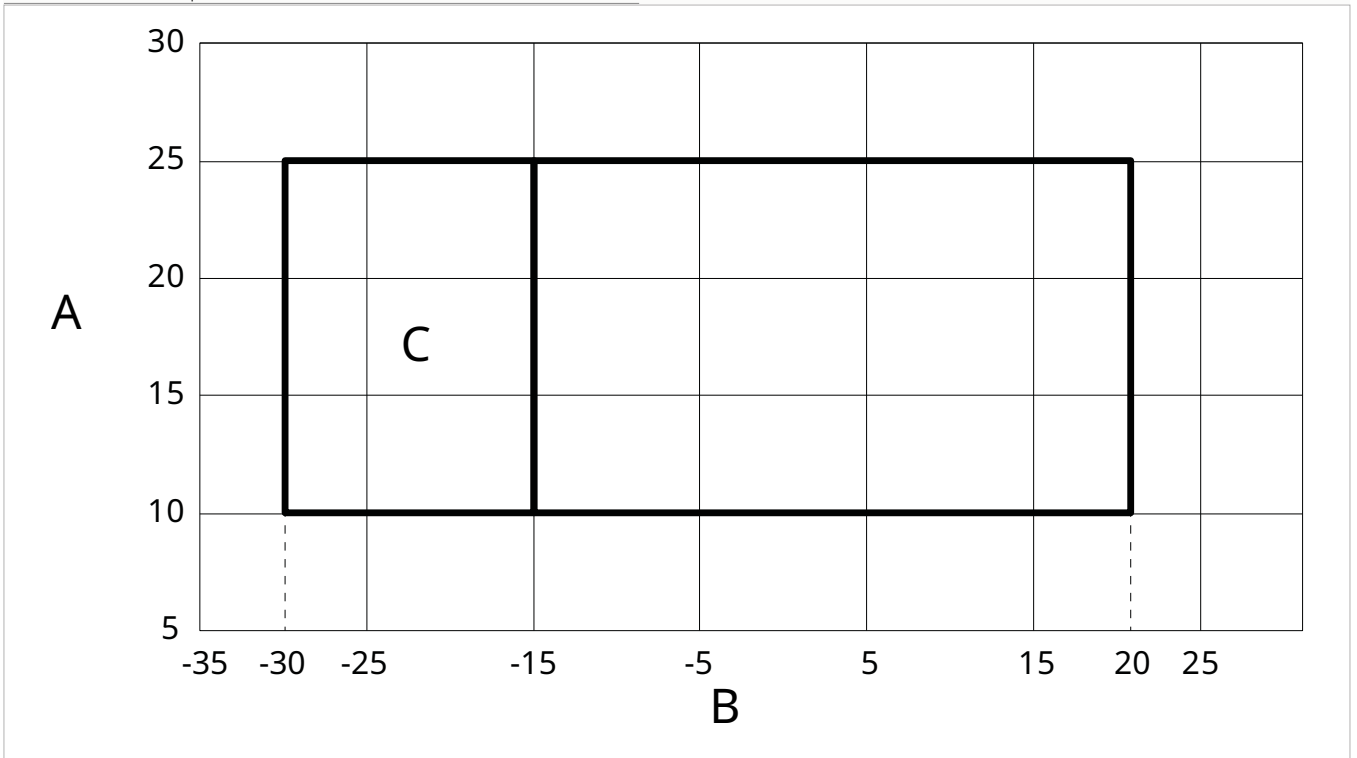
**Enthalpy version summer operating limits**

A Indoor temperature

B Outdoor temperature

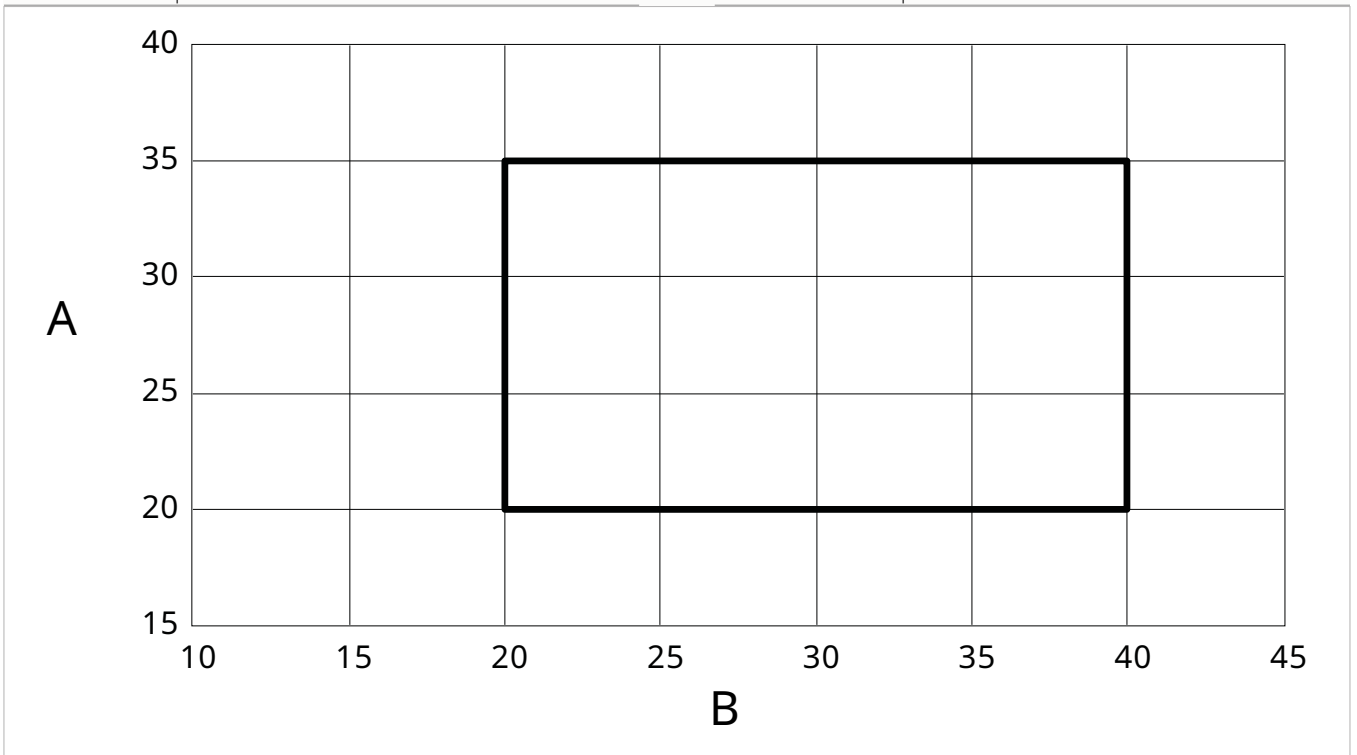

8.3 Dimensions

Size 08

A	Electrical panel	D	Filter port
B	Condensate drain	E	Circular couplings Ø 160 female
C	Power supply	F	Installation bracket

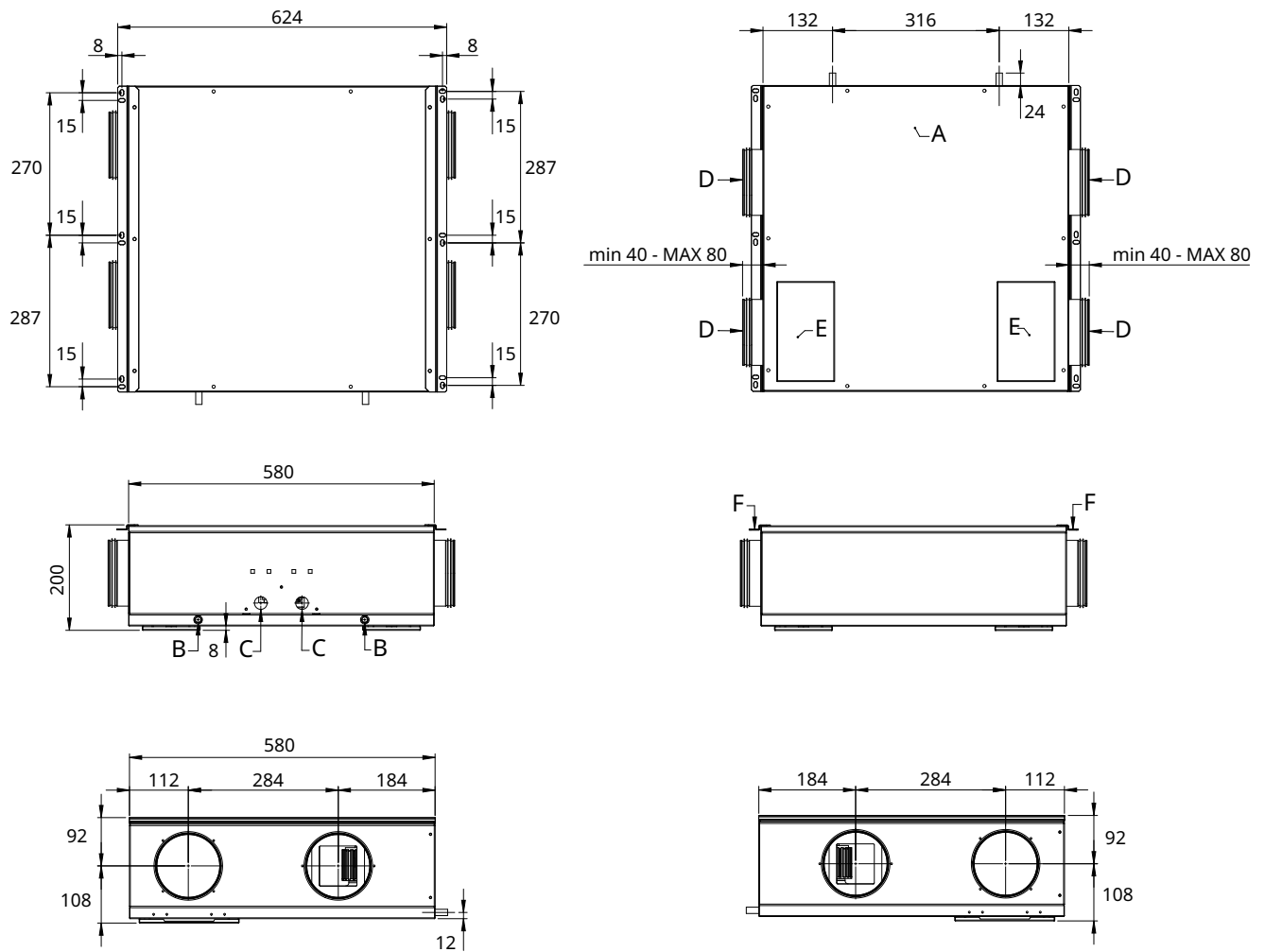

Size 10 - 15

- A** Electrical panel
- B** Condensate drain
- C** Power supply

- D** Filter port
- E** Circular couplings Ø 160 female
- F** Installation bracket

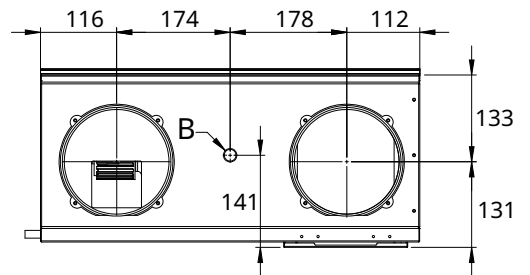
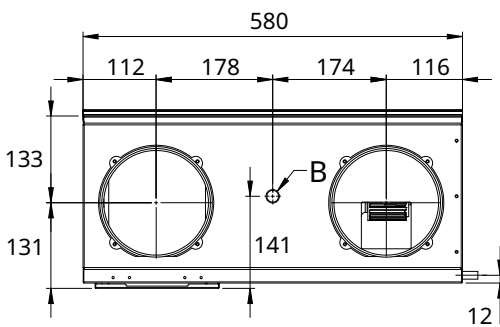
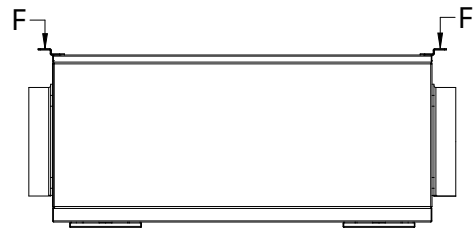
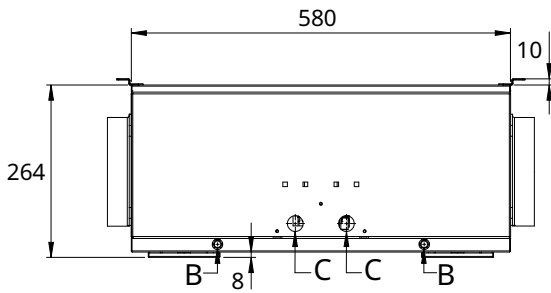
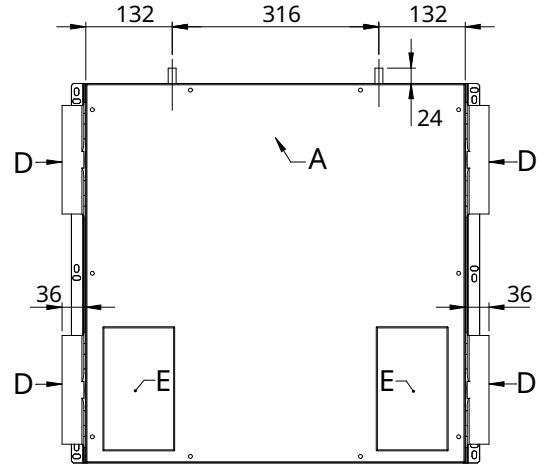
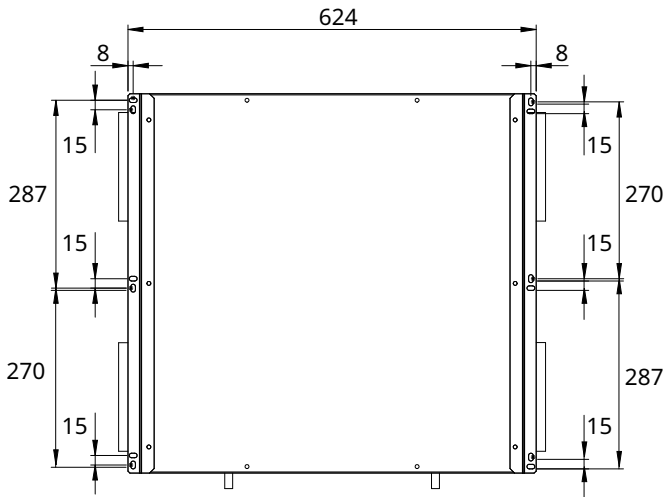

Size 15

A	Electrical panel
B	Condensate drain
C	Power supply

D	Filter port
E	Circular couplings Ø 160 female
F	Installation bracket

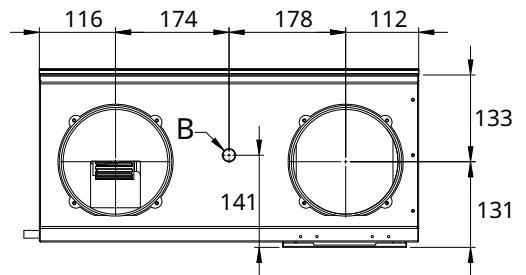
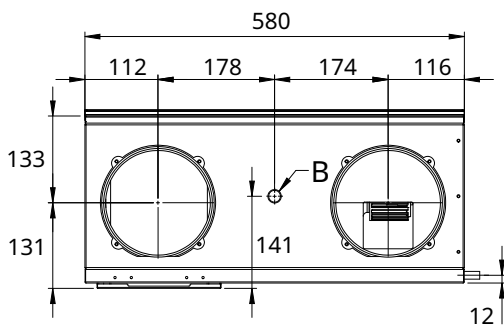
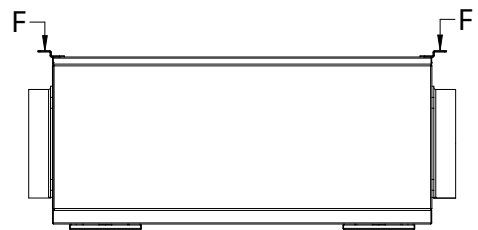
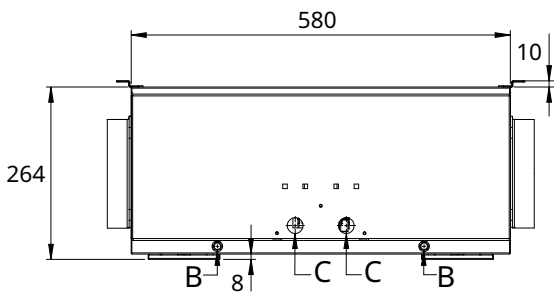
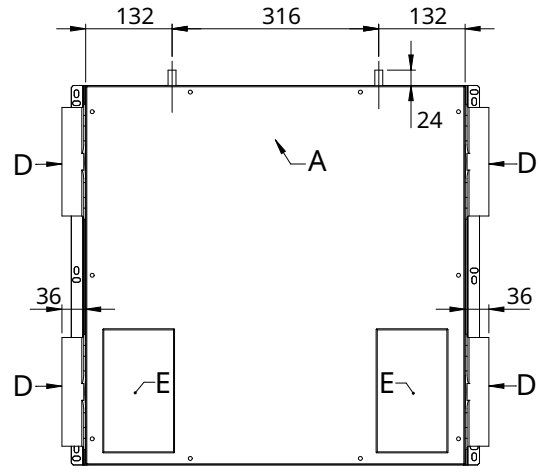
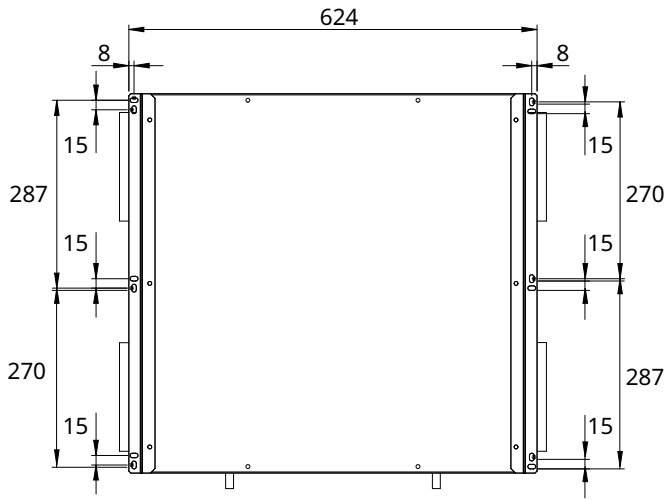

Size 20 - 25

- A** Electrical panel
- B** Condensate drain
- C** Power supply

- D** Filter port
- E** Circular couplings Ø 160 female
- F** Installation bracket

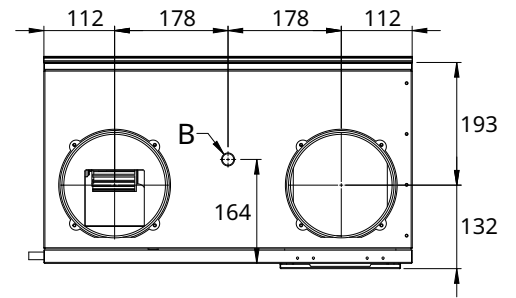
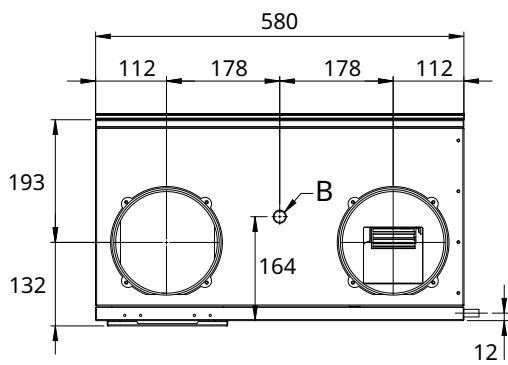
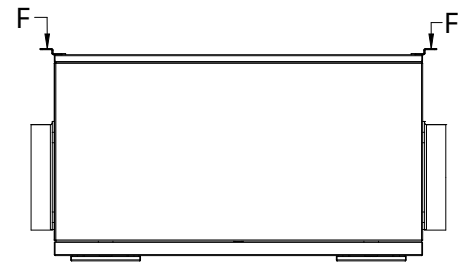
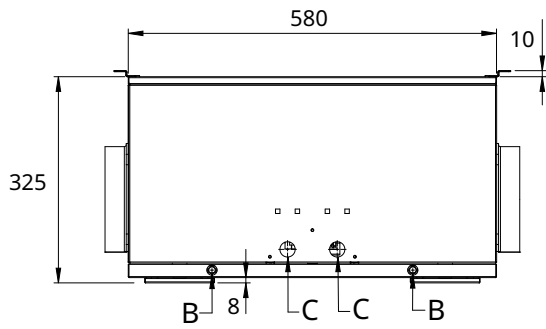
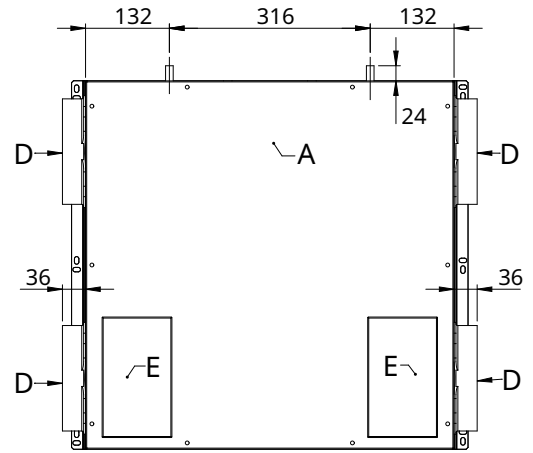
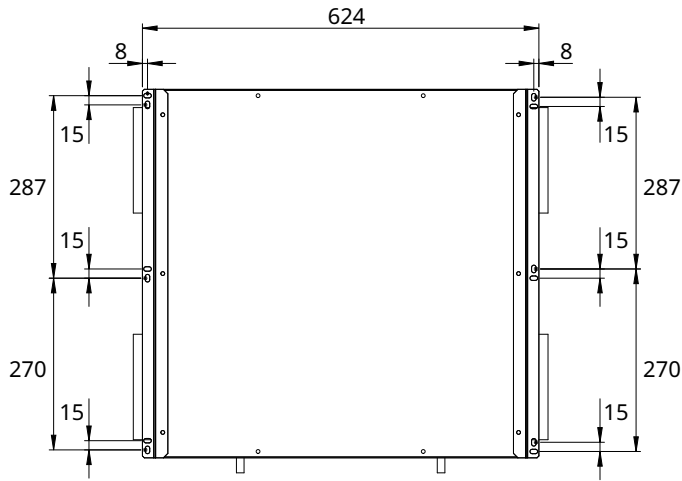

Size 25

- A** Electrical panel
- B** Condensate drain
- C** Power supply

- D** Filter port
- E** Circular couplings Ø 160 female
- F** Installation bracket

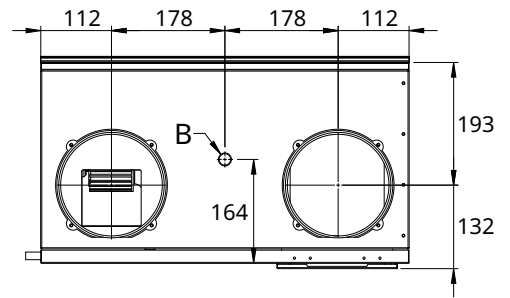
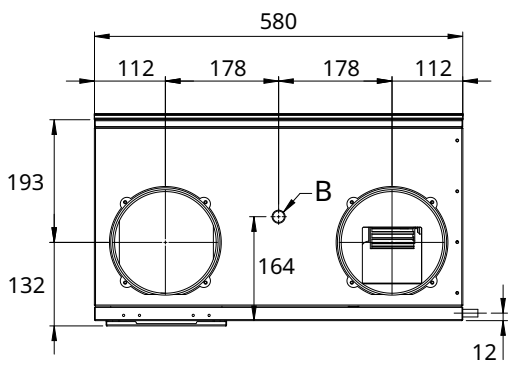
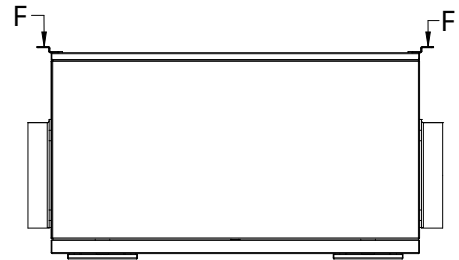
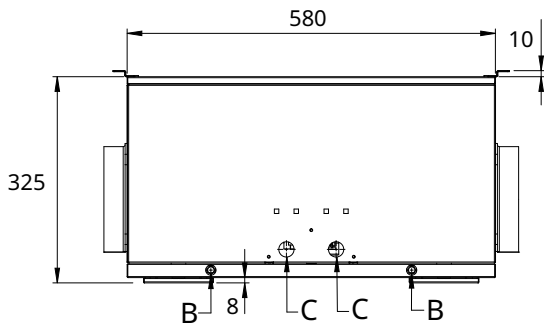
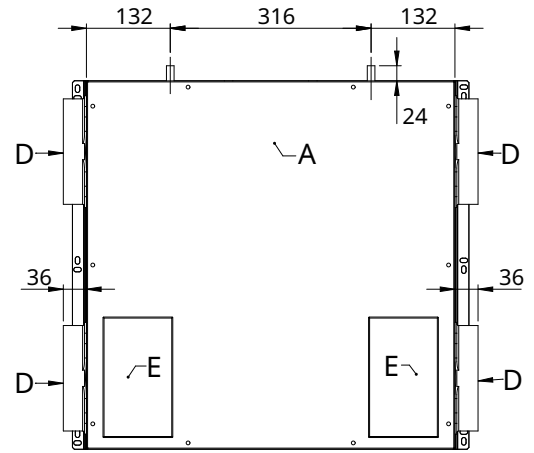
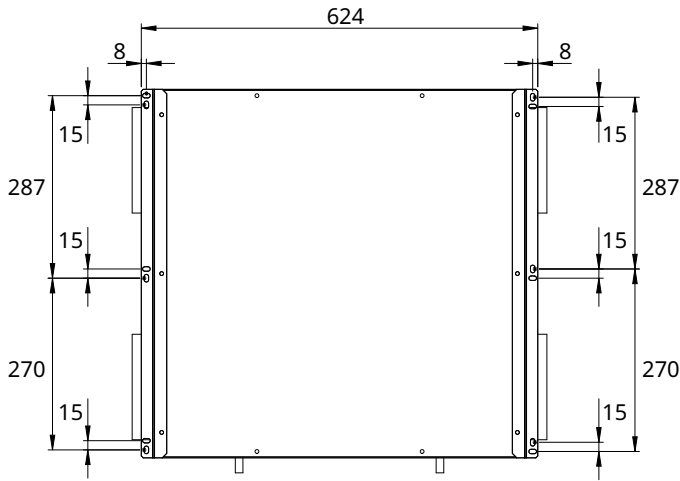

8.4 Ecodesign classification

Models	u.m.	08-Z
ECODESIGN ErP data (1)		
Supplier's name		SINERGIA srl
Model identifier		HRP DOMO+ SMALL 08 Z
Cold specific energy consumption SEC	kWh/ (m ² □a)	-78,05
Average specific energy consumption SEC	kWh/ (m ² □a)	-39,27
Warm specific energy consumption SEC	kWh/ (m ² □a)	-14,41
SEC class		A
Declared typology		RVU - Bidirectional
Type of drive		Variable speed
Type of heat recovery		Recuperative
Thermal efficiency	%	89,6
Maximum flow rate	m ³ /h	108
Power input	W	41
LWA sound power level	dB(A)	49
Reference flow rate	m ³ /s	0,0213
Reference pressure	Pa	50
SPI Specific power input	W/m ³ /h	0,280
CTRL control factor		0,85
Internal maximum leakage	%	2,0
External maximum leakage	%	1,7
Position and description of visual filter warning		Sybolized message on unit display and control panel and the instruction manual
Internet address for disassembly instructions		www.sinergia-srl.it
Cold annual electricity consumption AEC	kWh/year	840,58
Average annual electricity consumption AEC	kWh/year	303,58
Warm annual electricity consumption AEC	kWh/year	258,58
Cold annual heating saved AHS	kWh/year	9033,57
Average annual heating saved AHS	kWh/year	4617,76
Warm annual heating saved AHS	kWh/year	2088,09
1. Product fiche for RVU per EU Regulation No. 1254/2014		

Models	u.m.	08-ZX
ECODESIGN ErP data (1)		
Supplier's name		SINERGIA srl
Model identifier		HRP DOMO+ SMALL 08 ZX
Cold specific energy consumption SEC	kWh/ (m ² □a)	-71,71
Average specific energy consumption SEC	kWh/ (m ² □a)	-36,02
Warm specific energy consumption SEC	kWh/ (m ² □a)	-12,95
SEC class		A
Declared typology		RVU - Bidirectional
Type of drive		Variable speed
Type of heat recovery		Recuperative
Thermal efficiency	%	77,6
Maximum flow rate	m ³ /h	108
Power input	W	41
LWA sound power level	dB(A)	49
Reference flow rate	m ³ /s	0,0213
Reference pressure	Pa	50
SPI Specific power input	W/m ³ /h	0,285
CTRL control factor		0,85
Internal maximum leakage	%	2,0
External maximum leakage	%	1,7
Position and description of visual filter warning		Sybolized message on unit display and control panel and the instruction manual
Internet address for disassembly instructions		www.sinergia-srl.it
Cold annual electricity consumption AEC	kWh/year	840,58
Average annual electricity consumption AEC	kWh/year	303,58
Warm annual electricity consumption AEC	kWh/year	258,58
Cold annual heating saved AHS	kWh/year	9033,57
Average annual heating saved AHS	kWh/year	4617,76
Warm annual heating saved AHS	kWh/year	2088,09
1. Product fiche for RVU per EU Regulation No. 1254/2014		

Models	u.m.	10-Z
ECODESIGN ErP data (1)		
Supplier's name		SINERGIA srl
Model identifier		HRP DOMO+ SMALL 10 Z
Cold specific energy consumption SEC	kWh/ (m ² □a)	-77,71
Average specific energy consumption SEC	kWh/ (m ² □a)	-39,57
Warm specific energy consumption SEC	kWh/ (m ² □a)	-15,10
SEC class		A
Declared typology		RVU - Bidirectional
Type of drive		Variable speed
Type of heat recovery		Recuperative
Thermal efficiency	%	87,1
Maximum flow rate	m ³ /h	130
Power input	W	80
LWA sound power level	dB(A)	48
Reference flow rate	m ³ /s	0,0253
Reference pressure	Pa	50
SPI Specific power input	W/m ³ /h	0,242
CTRL control factor		0,85
Internal maximum leakage	%	1,9
External maximum leakage	%	1,6
Position and description of visual filter warning		Sybolized message on unit display and control panel and the instruction manual
Internet address for disassembly instructions		www.sinergia-srl.it
Cold annual electricity consumption AEC	kWh/year	800,81
Average annual electricity consumption AEC	kWh/year	263,81
Warm annual electricity consumption AEC	kWh/year	218,81
Cold annual heating saved AHS	kWh/year	8900,63
Average annual heating saved AHS	kWh/year	4549,81
Warm annual heating saved AHS	kWh/year	2057,36
1. Product fiche for RVU per EU Regulation No. 1254/2014		

Models	u.m.	10-ZX
ECODESIGN ErP data (1)		
Supplier's name		SINERGIA srl
Model identifier		HRP DOMO+ SMALL 10 ZX
Cold specific energy consumption SEC	kWh/ (m ² Da)	-73,26
Average specific energy consumption SEC	kWh/ (m ² Da)	-37,21
Warm specific energy consumption SEC	kWh/ (m ² Da)	-13,93
SEC class		A
Declared typology		RVU - Bidirectional
Type of drive		Variable speed
Type of heat recovery		Recuperative
Thermal efficiency	%	79,0
Maximum flow rate	m ³ /h	120
Power input	W	80
LWA sound power level	dB(A)	48
Reference flow rate	m ³ /s	0,0233
Reference pressure	Pa	50
SPI Specific power input	W/m ³ /h	0,250
CTRL control factor		0,85
Internal maximum leakage	%	2,0
External maximum leakage	%	1,7
Position and description of visual filter warning		Sybolized message on unit display and control panel and the instruction manual
Internet address for disassembly instructions		www.sinergia-srl.it
Cold annual electricity consumption AEC	kWh/year	808,27
Average annual electricity consumption AEC	kWh/year	271,27
Warm annual electricity consumption AEC	kWh/year	226,27
Cold annual heating saved AHS	kWh/year	8474,26
Average annual heating saved AHS	kWh/year	4331,86
Warm annual heating saved AHS	kWh/year	1958,81
1. Product fiche for RVU per EU Regulation No. 1254/2014		

Models	u.m.	15-Z
ECODESIGN ErP data (1)		
Supplier's name		SINERGIA srl
Model identifier		HRP DOMO+ SMALL 15 Z
Cold specific energy consumption SEC	kWh/ (m ² □a)	-75,11
Average specific energy consumption SEC	kWh/ (m ² □a)	-37,45
Warm specific energy consumption SEC	kWh/ (m ² □a)	-13,26
SEC class		A
Declared typology		RVU - Bidirectional
Type of drive		Variable speed
Type of heat recovery		Recuperative
Thermal efficiency	%	85,2
Maximum flow rate	m ³ /h	210
Power input	W	140
LWA sound power level	dB(A)	51
Reference flow rate	m ³ /s	0,0408
Reference pressure	Pa	50
SPI Specific power input	W/m ³ /h	0,313
CTRL control factor		0,85
Internal maximum leakage	%	1,7
External maximum leakage	%	1,4
Position and description of visual filter warning		Sybolized message on unit display and control panel and the instruction manual
Internet address for disassembly instructions		www.sinergia-srl.it
Cold annual electricity consumption AEC	kWh/year	865,22
Average annual electricity consumption AEC	kWh/year	328,22
Warm annual electricity consumption AEC	kWh/year	283,22
Cold annual heating saved AHS	kWh/year	8801,06
Average annual heating saved AHS	kWh/year	4498,91
Warm annual heating saved AHS	kWh/year	2034,35
1. Product fiche for RVU per EU Regulation No. 1254/2014		

Models	u.m.	15-ZX
ECODESIGN ErP data (1)		
Supplier's name		SINERGIA srl
Model identifier		HRP DOMO+ SMALL 15 ZX
Cold specific energy consumption SEC	kWh/ (m ² □a)	-69,73
Average specific energy consumption SEC	kWh/ (m ² □a)	-34,71
Warm specific energy consumption SEC	kWh/ (m ² □a)	-12,02
SEC class		A
Declared typology		RVU - Bidirectional
Type of drive		Variable speed
Type of heat recovery		Recuperative
Thermal efficiency	%	75,0
Maximum flow rate	m ³ /h	160
Power input	W	80
LWA sound power level	dB(A)	50
Reference flow rate	m ³ /s	0,0311
Reference pressure	Pa	50
SPI Specific power input	W/m ³ /h	0,313
CTRL control factor		0,85
Internal maximum leakage	%	1,9
External maximum leakage	%	1,6
Position and description of visual filter warning		Sybolized message on unit display and control panel and the instruction manual
Internet address for disassembly instructions		www.sinergia-srl.it
Cold annual electricity consumption AEC	kWh/year	864,83
Average annual electricity consumption AEC	kWh/year	327,83
Warm annual electricity consumption AEC	kWh/year	282,83
Cold annual heating saved AHS	kWh/year	8262,40
Average annual heating saved AHS	kWh/year	4223,56
Warm annual heating saved AHS	kWh/year	1909,84
1. Product fiche for RVU per EU Regulation No. 1254/2014		

Models	u.m.	20-Z
ECODESIGN ErP data (1)		
Supplier's name		SINERGIA srl
Model identifier		HRP DOMO+ SMALL 20 Z
Cold specific energy consumption SEC	kWh/ (m ² □a)	-76,80
Average specific energy consumption SEC	kWh/ (m ² □a)	-38,78
Warm specific energy consumption SEC	kWh/ (m ² □a)	-14,37
SEC class		A
Declared typology		RVU - Bidirectional
Type of drive		Variable speed
Type of heat recovery		Recuperative
Thermal efficiency	%	86,6
Maximum flow rate	m ³ /h	200
Power input	W	120
LWA sound power level	dB(A)	48
Reference flow rate	m ³ /s	0,0389
Reference pressure	Pa	50
SPI Specific power input	W/m ³ /h	0,271
CTRL control factor		0,85
Internal maximum leakage	%	1,8
External maximum leakage	%	1,6
Position and description of visual filter warning		Sybolized message on unit display and control panel and the instruction manual
Internet address for disassembly instructions		www.sinergia-srl.it
Cold annual electricity consumption AEC	kWh/year	827,66
Average annual electricity consumption AEC	kWh/year	290,66
Warm annual electricity consumption AEC	kWh/year	245,66
Cold annual heating saved AHS	kWh/year	8876,80
Average annual heating saved AHS	kWh/year	4537,63
Warm annual heating saved AHS	kWh/year	2051,86
1. Product fiche for RVU per EU Regulation No. 1254/2014		

Models	u.m.	20-ZX
ECODESIGN ErP data (1)		
Supplier's name		SINERGIA srl
Model identifier		HRP DOMO+ SMALL 20 ZX
Cold specific energy consumption SEC	kWh/ (m ² Da)	-72,81
Average specific energy consumption SEC	kWh/ (m ² Da)	-36,76
Warm specific energy consumption SEC	kWh/ (m ² Da)	-13,48
SEC class		A
Declared typology		RVU - Bidirectional
Type of drive		Variable speed
Type of heat recovery		Recuperative
Thermal efficiency	%	79,0
Maximum flow rate	m ³ /h	180
Power input	W	120
LWA sound power level	dB(A)	48
Reference flow rate	m ³ /s	0,0350
Reference pressure	Pa	50
SPI Specific power input	W/m ³ /h	0,270
CTRL control factor		0,85
Internal maximum leakage	%	2,0
External maximum leakage	%	1,7
Position and description of visual filter warning		Sybolized message on unit display and control panel and the instruction manual
Internet address for disassembly instructions		www.sinergia-srl.it
Cold annual electricity consumption AEC	kWh/year	826,22
Average annual electricity consumption AEC	kWh/year	289,22
Warm annual electricity consumption AEC	kWh/year	244,22
Cold annual heating saved AHS	kWh/year	8474,26
Average annual heating saved AHS	kWh/year	4331,86
Warm annual heating saved AHS	kWh/year	1958,81
1. Product fiche for RVU per EU Regulation No. 1254/2014		

Models	u.m.	25-Z
ECODESIGN ErP data (1)		
Supplier's name		SINERGIA srl
Model identifier		HRP DOMO+ SMALL 25 Z
Cold specific energy consumption SEC	kWh/ (m ² Da)	-74,86
Average specific energy consumption SEC	kWh/ (m ² Da)	-36,84
Warm specific energy consumption SEC	kWh/ (m ² Da)	-12,43
SEC class		A
Declared typology		RVU - Bidirectional
Type of drive		Variable speed
Type of heat recovery		Recuperative
Thermal efficiency	%	86,6
Maximum flow rate	m ³ /h	320
Power input	W	250
LWA sound power level	dB(A)	48
Reference flow rate	m ³ /s	0,0622
Reference pressure	Pa	50
SPI Specific power input	W/m ³ /h	0,357
CTRL control factor		0,85
Internal maximum leakage	%	1,8
External maximum leakage	%	1,6
Position and description of visual filter warning		Sybolized message on unit display and control panel and the instruction manual
Internet address for disassembly instructions		www.sinergia-srl.it
Cold annual electricity consumption AEC	kWh/year	905,24
Average annual electricity consumption AEC	kWh/year	368,24
Warm annual electricity consumption AEC	kWh/year	323,24
Cold annual heating saved AHS	kWh/year	8876,80
Average annual heating saved AHS	kWh/year	4537,63
Warm annual heating saved AHS	kWh/year	2051,86
1. Product fiche for RVU per EU Regulation No. 1254/2014		

Models	u.m.	25-ZX
ECODESIGN ErP data (1)		
Supplier's name		SINERGIA srl
Model identifier		HRP DOMO+ SMALL 25 ZX
Cold specific energy consumption SEC	kWh/ (m ² □a)	-69,68
Average specific energy consumption SEC	kWh/ (m ² □a)	-34,40
Warm specific energy consumption SEC	kWh/ (m ² □a)	-11,56
SEC class		A
Declared typology		RVU - Bidirectional
Type of drive		Variable speed
Type of heat recovery		Recuperative
Thermal efficiency	%	76,0
Maximum flow rate	m ³ /h	245
Power input	W	160
LWA sound power level	dB(A)	50
Reference flow rate	m ³ /s	0,0476
Reference pressure	Pa	50
SPI Specific power input	W/m ³ /h	0,338
CTRL control factor		0,85
Internal maximum leakage	%	1,5
External maximum leakage	%	1,2
Position and description of visual filter warning		Sybolized message on unit display and control panel and the instruction manual
Internet address for disassembly instructions		www.sinergia-srl.it
Cold annual electricity consumption AEC	kWh/year	888,08
Average annual electricity consumption AEC	kWh/year	351,08
Warm annual electricity consumption AEC	kWh/year	306,08
Cold annual heating saved AHS	kWh/year	8315,36
Average annual heating saved AHS	kWh/year	4250,63
Warm annual heating saved AHS	kWh/year	1922,08
1. Product fiche for RVU per EU Regulation No. 1254/2014		

9. ACCESSORIES

9.1 Electrical resistance

Description

The electric air heater accessory heats the air in the ventilation ducts. It can be installed for pre-heating the unit in

cold climates and for post-heating to increase the outlet air temperature and heat the rooms. It is a flexible solution to improve thermal comfort in ventilation systems. It is available in two capacities: 0.5 kW and 1.0 kW.

Dimensions

Electrical duct heater 0.5 kW, DN 160 mm

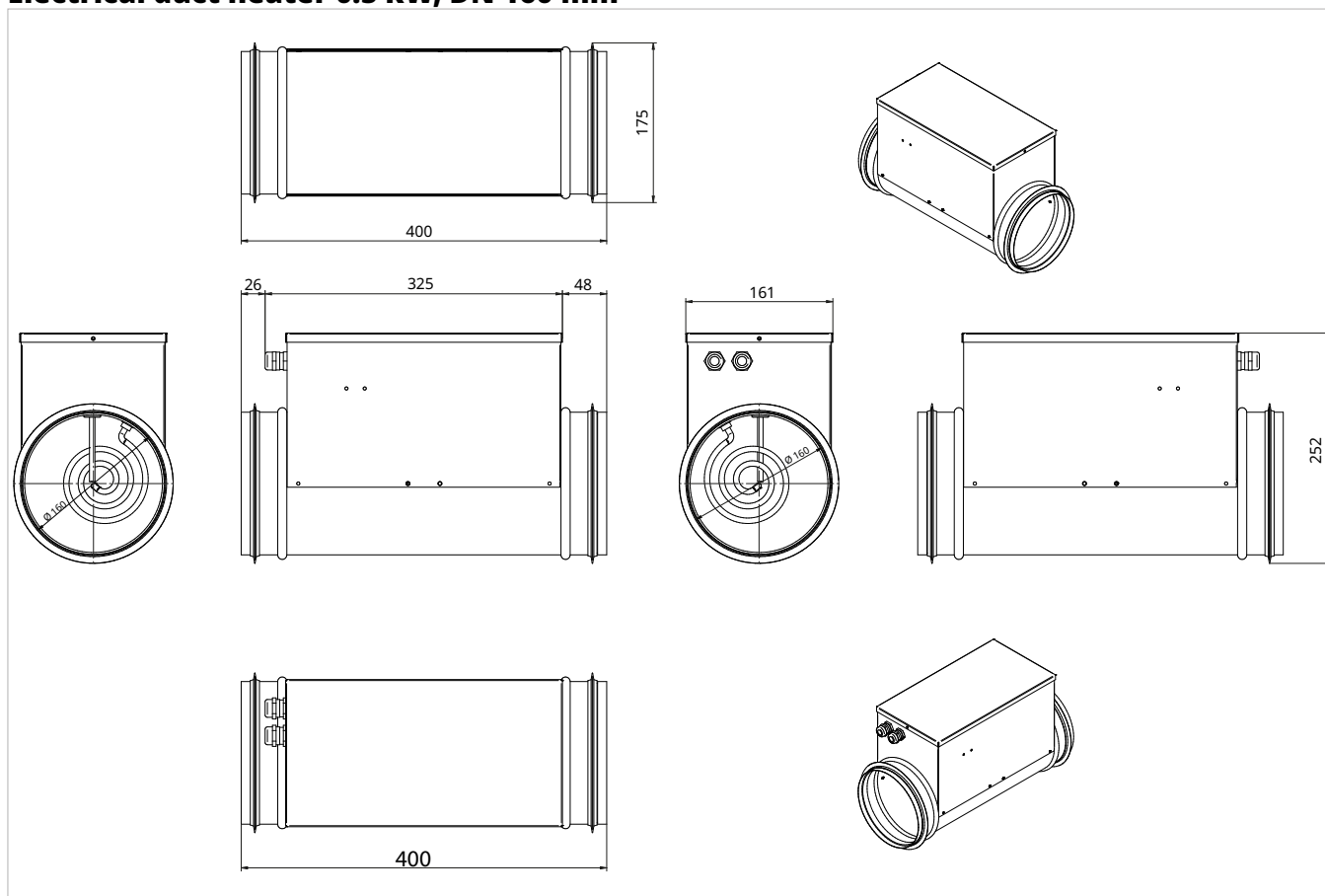

Electrical duct heater 1.0 kW, DN 160 mm

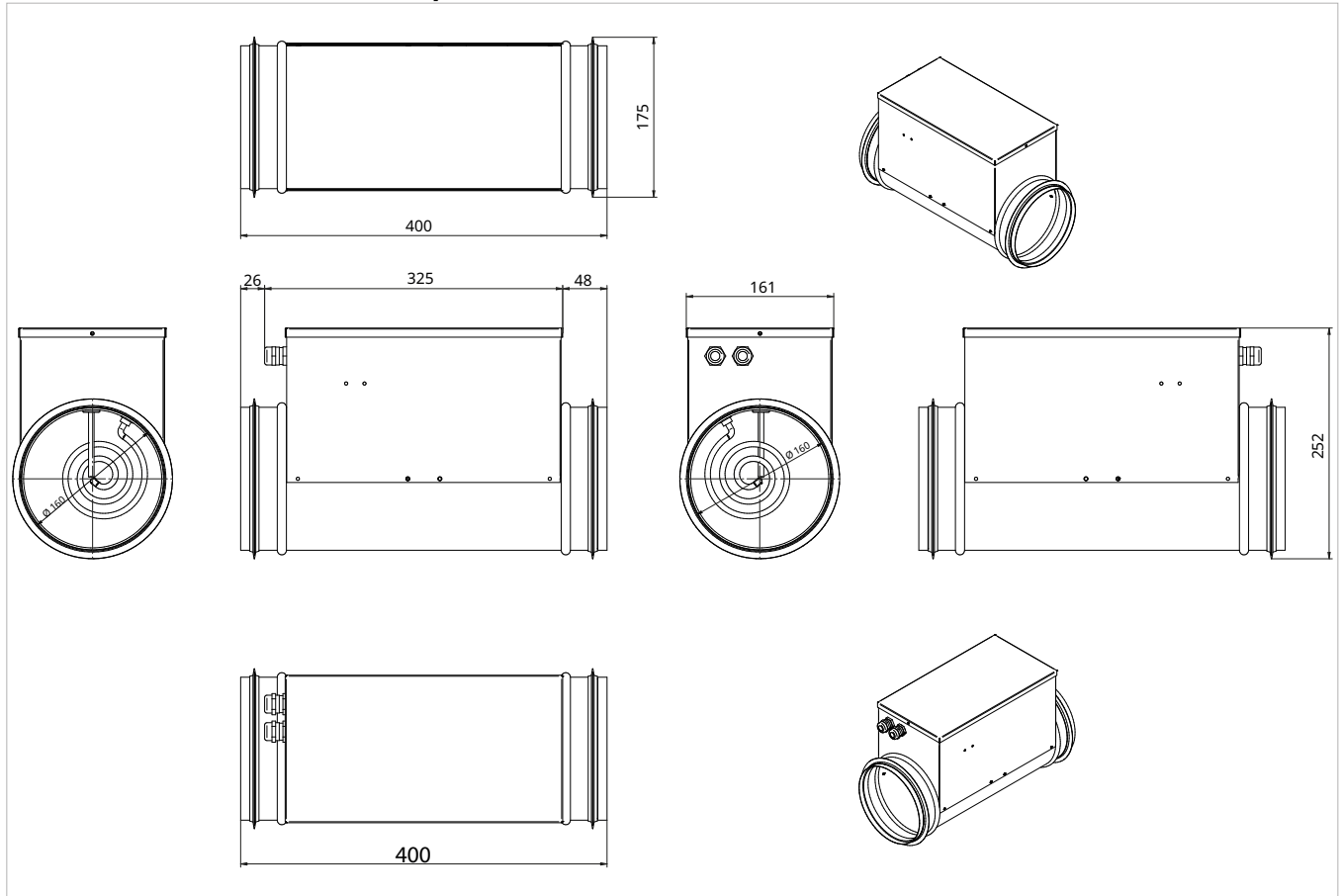

Wiring diagram

Wiring diagram

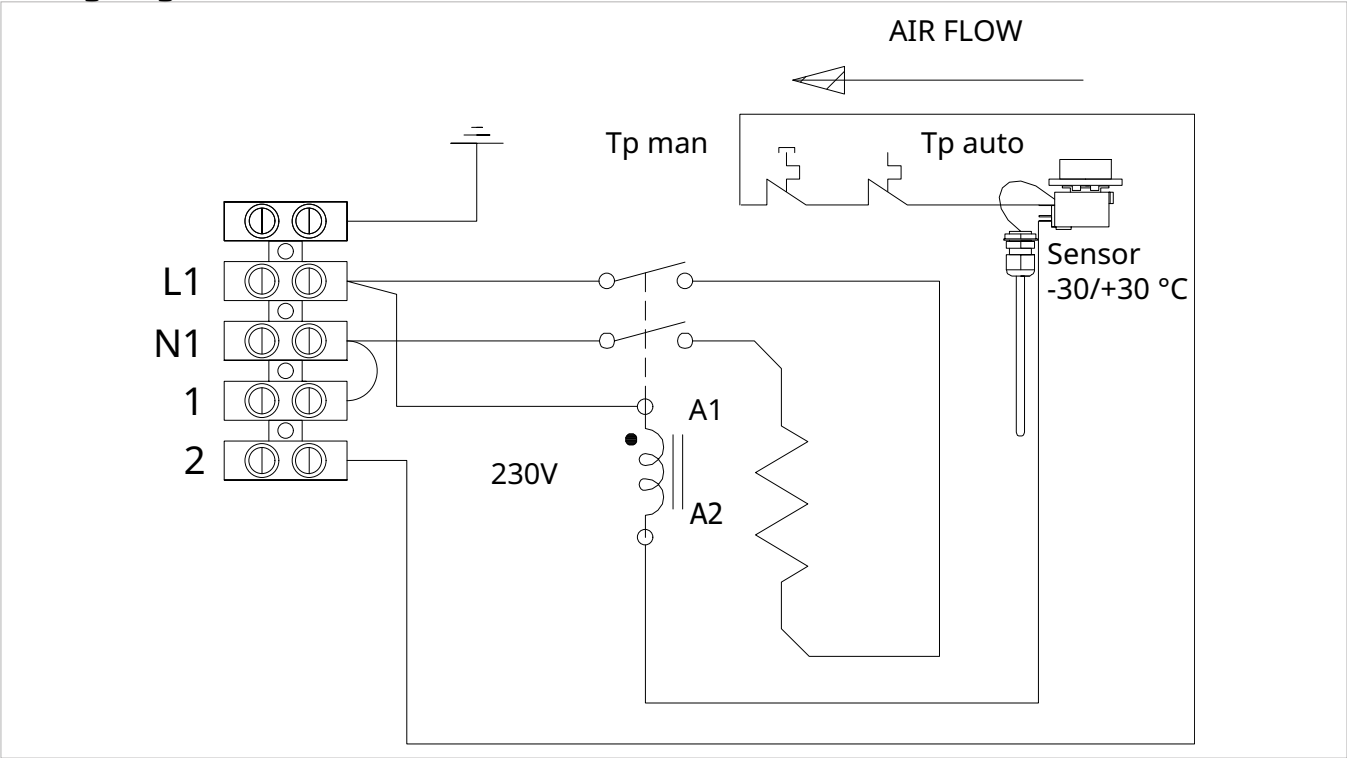

Connections to be made by the customer

L - N -PE	Unit power supply	230 / 1 / 50
1 - 2	Resistance On - Off contact	Voltage contact Contact closed (active resistance)

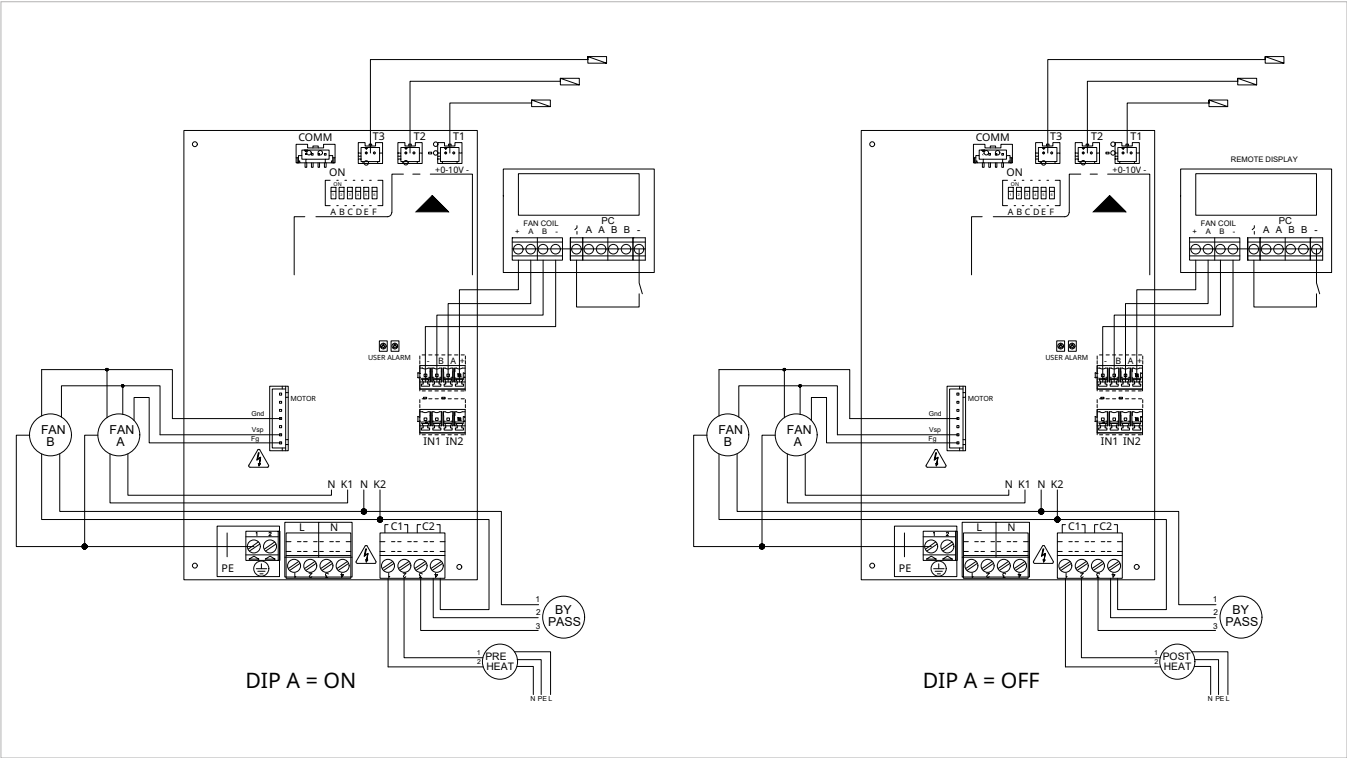

9.2 Valves for water coils

Wiring diagram

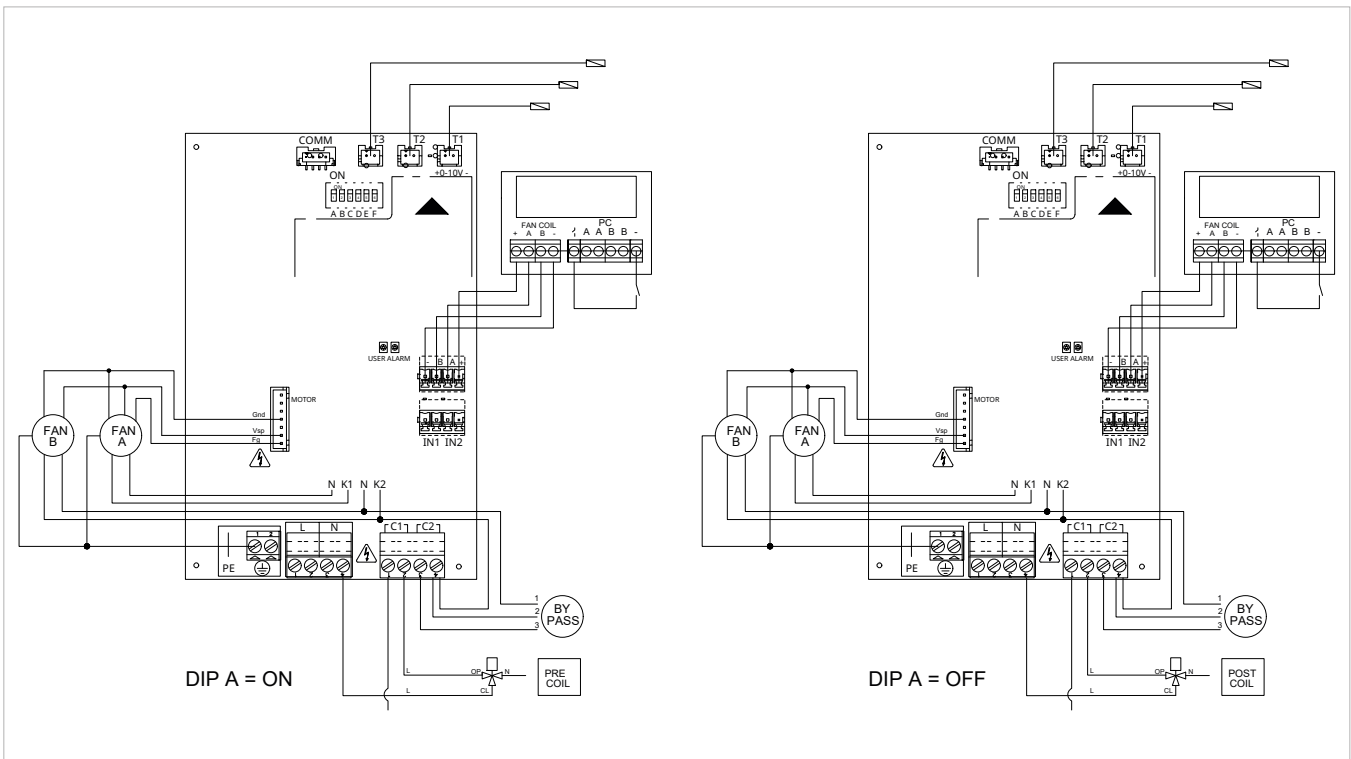
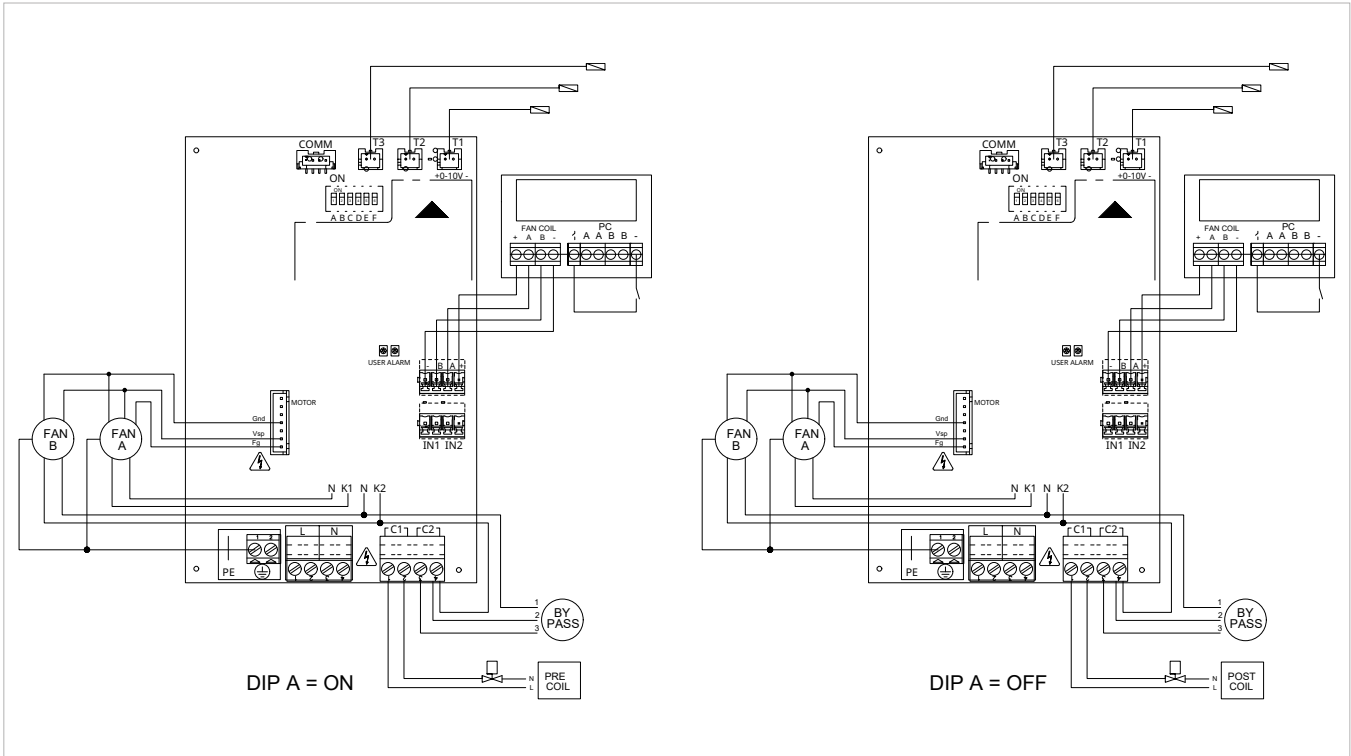

agix.fitt.com

VERS. 01/2025

FITT VENTILATION SOLUTIONS

È l'area di business del Gruppo FITT che sviluppa soluzioni professionali producendo sistemi completi di VMC (Ventilazione Meccanica Controllata) e di distribuzione dell'aria per garantire il comfort abitativo degli ambienti residenziali, il risparmio energetico e il benessere delle persone.

For more information:

AIRPLAST S.r.l. a sole shareholder company

Head Office: Via Piave, 8 – 36066 Sandrigo (VI), Italy

Warehouse - Production: Via Aldo Moro, 10 – 36060 Pianezze (VI), Italy

Tel: +39 0424-1909736 | airplast.it

Produced by: Sinergia S.r.l. - Via del Commercio 1/A - 23017 Morbegno (SO) - Italy